

Maths Summer 2

Year 10 Higher

Blended Learning Booklet

Name:

Form:

Each week covers topics you would complete in your 3 Maths lessons that week. Write out the title and LI and then complete the tasks.

All video links are online using the ClassCharts link.

The Knowledge Organiser on page 4 has further practice questions and page numbers linking to your pocket revision guides for all the key information and examples to help you with this unit.

Upload all work onto ClassCharts for feedback.

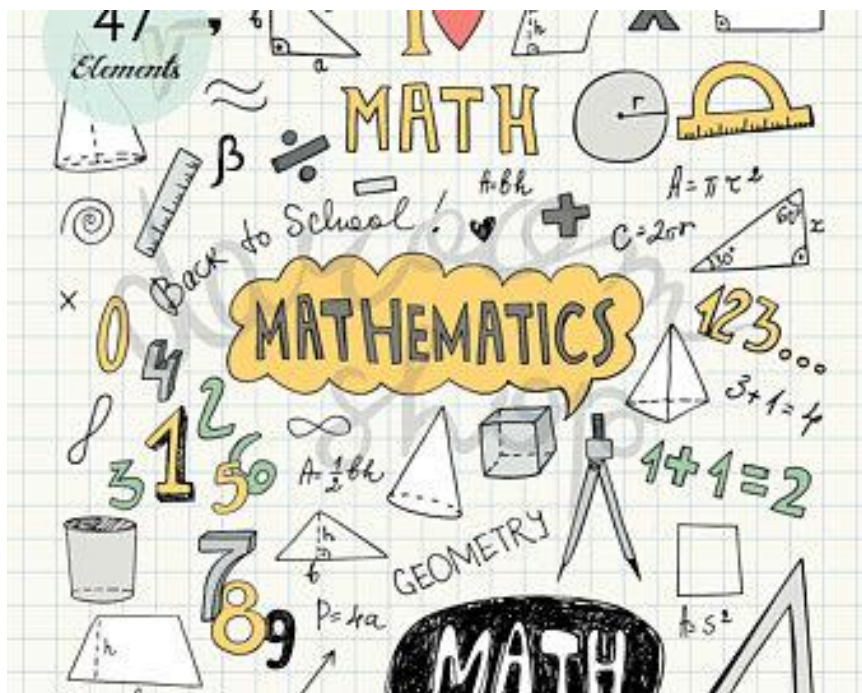

Contents

Page 3: Big Picture - Year 10 Overview

Page 4: Knowledge Organiser

Page 5 – 10: Week 1 – Coordinate Geometry

Page 11 – 18: Week 2 – Linear Graphs

Page 18 – 24: Week 3 – Linear & Quadratic Graphs

Page 25 – 31: Week 4 – Cubic & Reciprocal Graphs, Transformations

Page 32 – 40: Week 5 – Transformations

Page 41 – 46: Week 6 – Transformations, Sectors and Arcs

Page 47: Assessment Ladder



Big Picture – Year 10 Higher Overview Mathematics Department

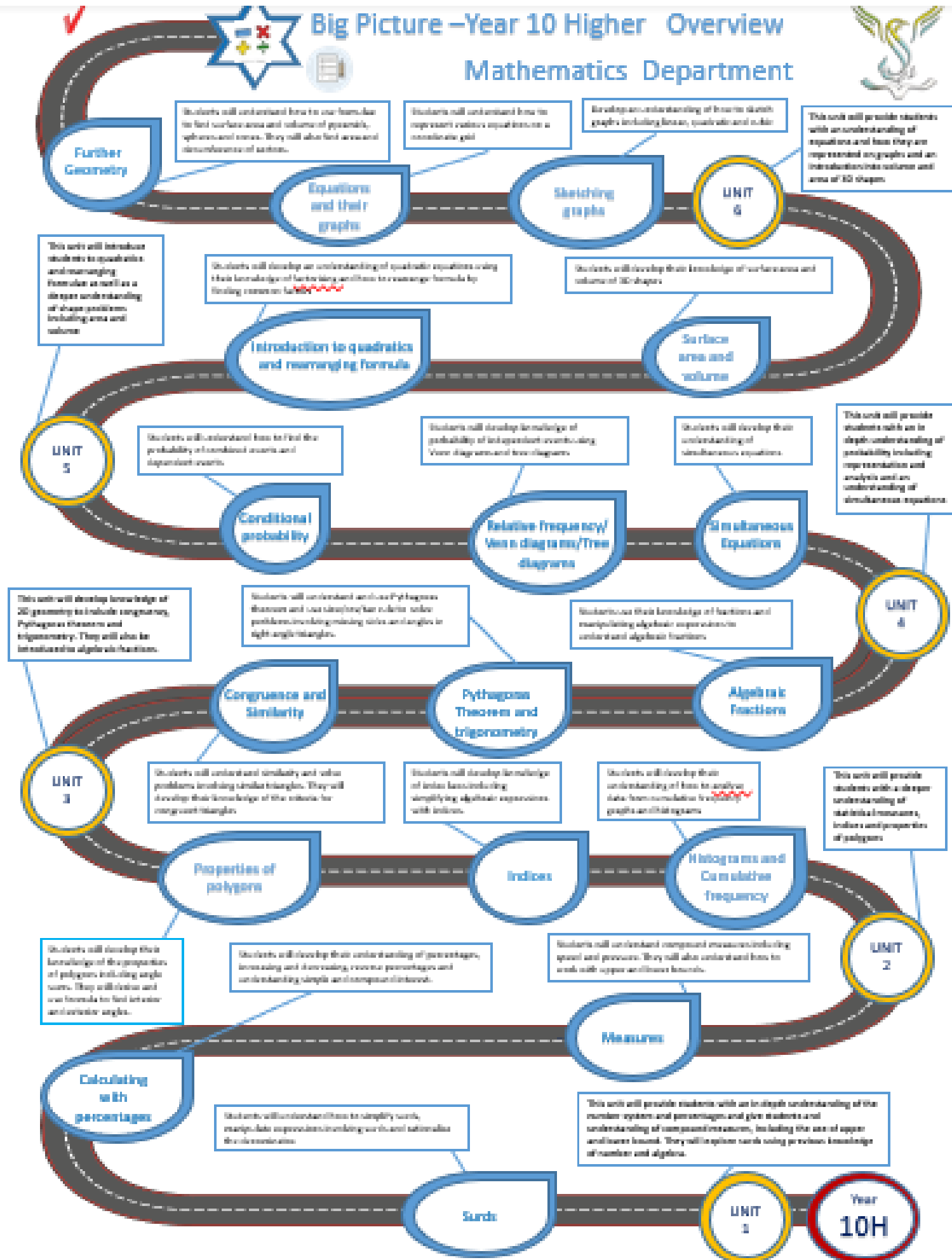



Year 10 - Higher

Summer Two

Sketching graphs, Linear and quadratic graphs, Geometry recap

Revision Guide pages:

Sketching graphs – 62,63
 Linear and quadratic graphs – 55, 56, 60, 61
 Geometry recap – 86-88, 94-97, 90-91

Task 3a – Solve these quadratic equations by factorising

- a) $x^2 - x = 0$ f) $x^2 - 2x + 1 = 0$
 b) $x^2 - 2x = 0$ g) $x^2 - 2x - 3 = 0$
 c) $2x^2 - x = 0$ h) $2x^2 - x - 3 = 0$
 d) $6x - 9x^2 = 0$ i) $3x^2 - 8x - 3 = 0$
 e) $x^2 + 2x + 1 = 0$ j) $6x^2 - 7x^2 - 3 = 0$

Task 3b – Sketch the graphs of part a and part g. label roots.

Task 1 Complete these tables of values and draw their graphs all on the same axis, make sure you label your lines.

$$y = -x$$

x	-4	-3	-2	-1	0	1	2	3	4
y									

$$x + y = 6$$

x	-4	-3	-2	-1	0	1	2	3	4
y									

$$y = 2x + 1$$

x	-4	-3	-2	-1	0	1	2	3	4
y									

$$y = -2x$$

x	-4	-3	-2	-1	0	1	2	3	4
y									

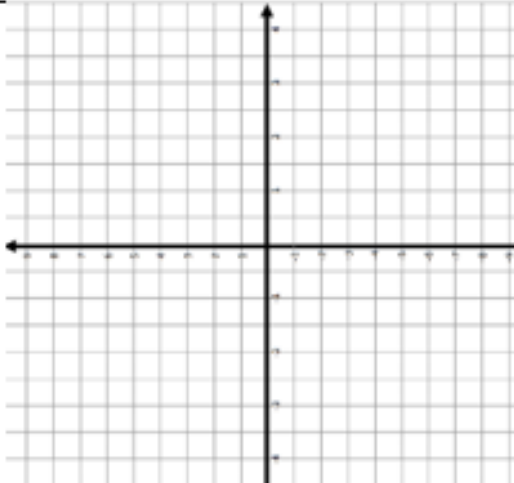

Task 2 Solve these equations

Section A

- 1 $4(3x - 2) = 56$ 1 $3x - 2 = 2x + 3$
 2 $5(3x + 2) = -5$ 2 $4x - 10 = x - 4$
 3 $2(3x + 4) = 50$ 3 $3x + 4 = x + 1$
 4 $5(6x + 1) = 305$ 4 $10x + 2 = 6x - 2$

Section C

- 1 $5x - 4 = 3(x + 4)$
 2 $4x - 8 = 3(x - 4)$
 3 $7x - 6 = 3(2x + 1)$
 4 $10x + 5 = 3(2x + 2)$

Section B

Task 4 Plot the quadratic functions

$$f(x) = x^2 + 1$$

x	-3	-2	-1	0	1	2	3
f(x)							

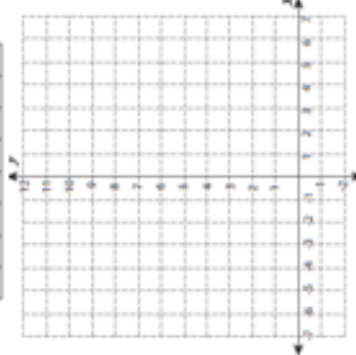

$$f(x) = 9x^2$$

x	-3	-2	-1	0	1	2	3
f(x)							

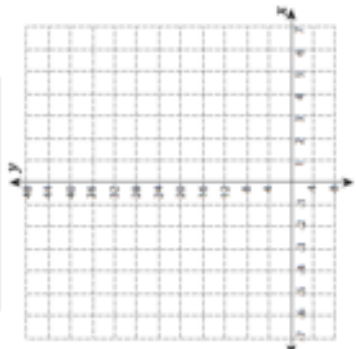

$$f(x) = -x^2$$

x	-3	-2	-1	0	1	2	3
f(x)							

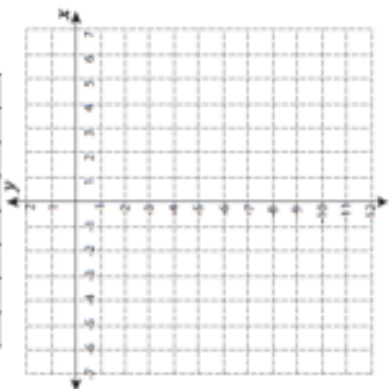

Task 5 Sketch the graphs of these linear functions, labelling the intercepts.

- $y = 2x$
- $y = 3x - 2$
- $y = -\frac{1}{2}x + 5$
- $y - x = 9$

Week 1:

- LI: I can find the midpoint of a line segment

Demonstration Videos:

<http://corbettmaths.com/2013/04/15/midpoint-of-a-line/>

Tasks:

Question 1: Find the coordinates of the midpoints of the following line segments.

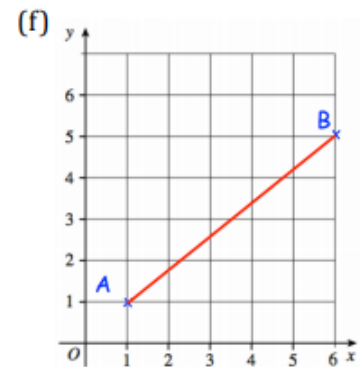
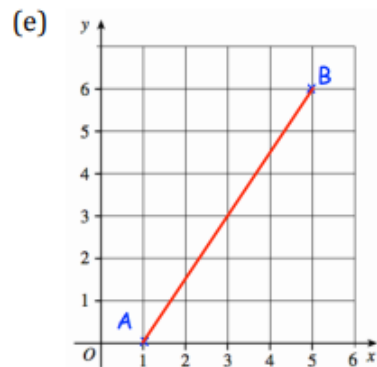
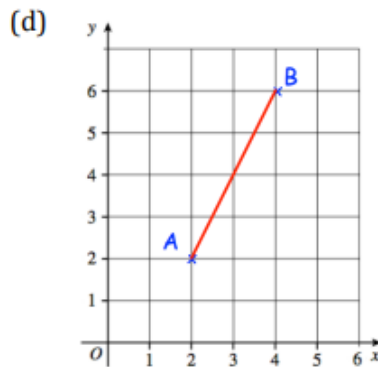
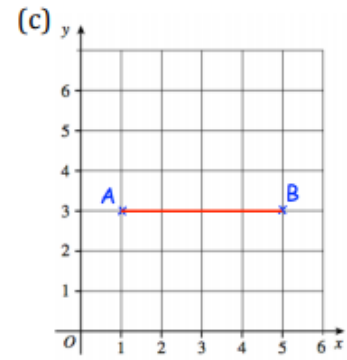
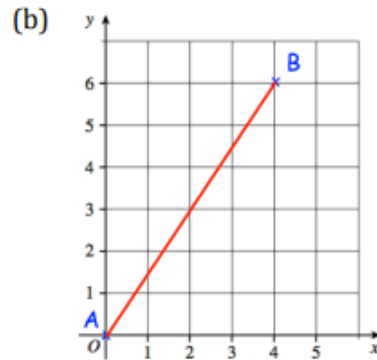
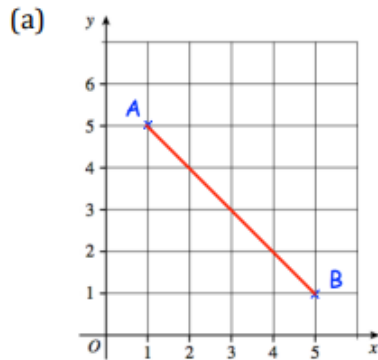

Question 2: Find the coordinates of the midpoints of the following line segments.

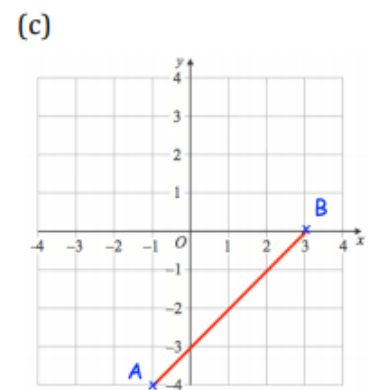
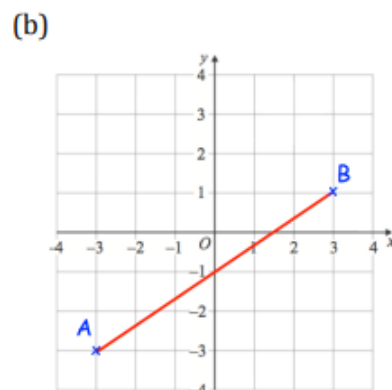
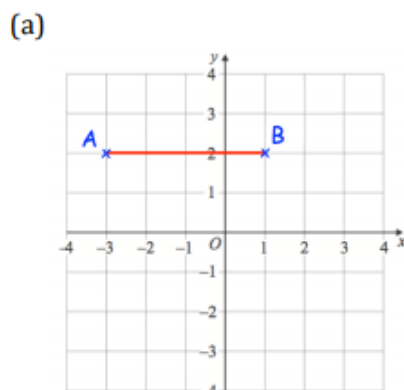

(d)

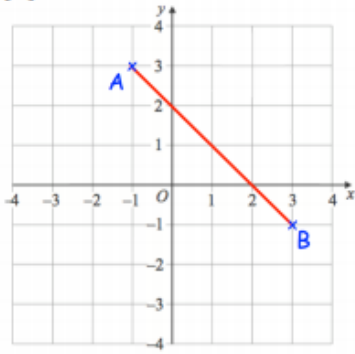

(e)

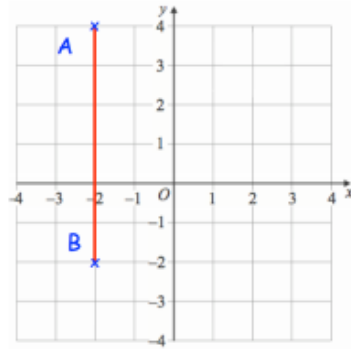

(f)

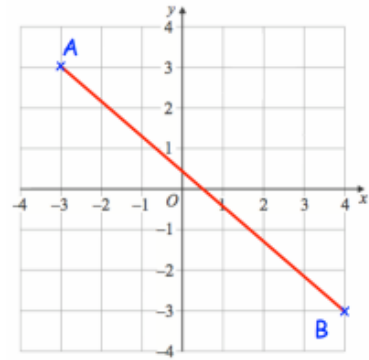

Question 3: Find the midpoint of the line joining these pairs of points

(a) $(2, 4)$ and $(6, 10)$

(b) $(1, 4)$ and $(9, 12)$

(c) $(0, 7)$ and $(6, 1)$

(d) $(-5, 2)$ and $(5, -4)$

(e) $(-3, 9)$ and $(7, -1)$

(f) $(0, -4)$ and $(9, 0)$

(g) $(-10, -6)$ and $(-2, 8)$

(h) $(0, 5)$ and $(-11, -10)$

(i) $(9, 8)$ and $(4, 8)$

Question 4: M is the midpoint of PQ in each diagram below. Find the coordinates of Q in each diagram.

(a)

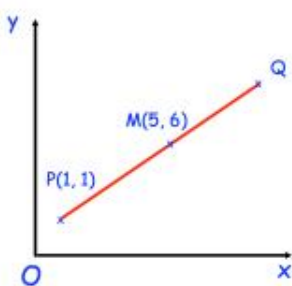

(b)

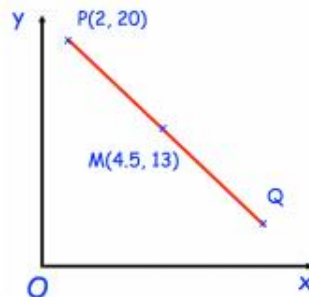

(c)

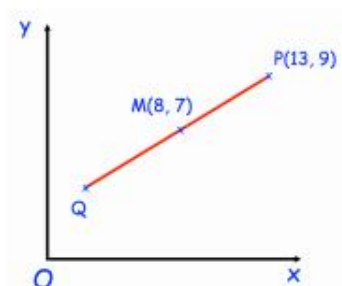

Question 5: M is the midpoint of PQ in each diagram below. Find the coordinates of Q in each diagram.

(a)

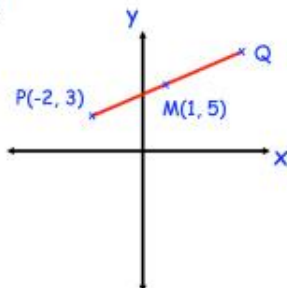

(b)

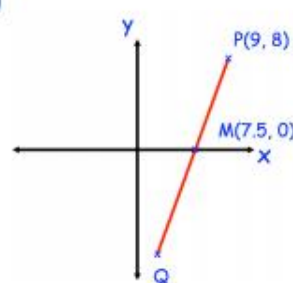

(c)

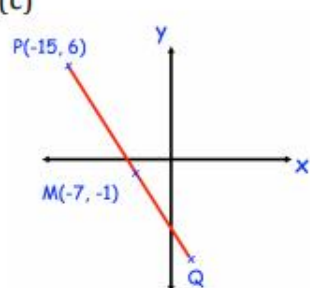

Week 1:

- LI: I can find the length of a line segment

Demonstration Videos:

<http://corbettmaths.com/2013/05/03/distance-between-two-coordinates/>

Tasks:

Question 1: Calculate the length of the line joining the points A and B.

(a)

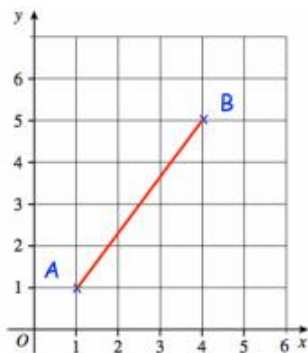

(b)

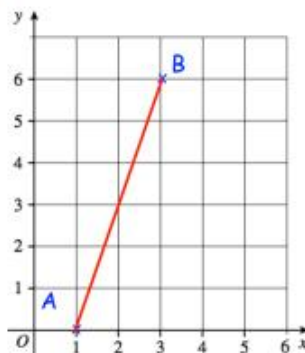

(c)

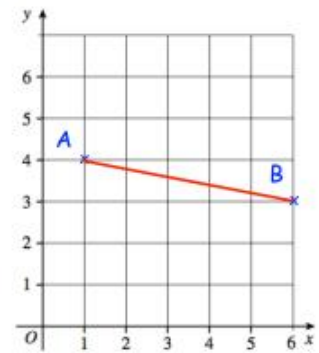

Question 2: Calculate the length of the line joining the points A and B.

(a)

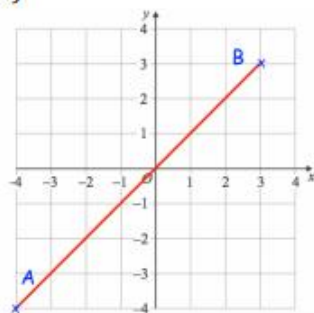

(b)

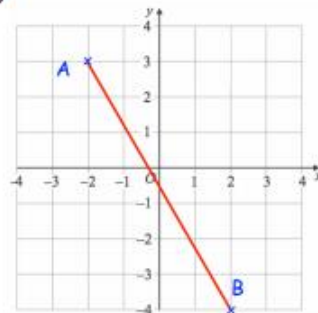

(c)

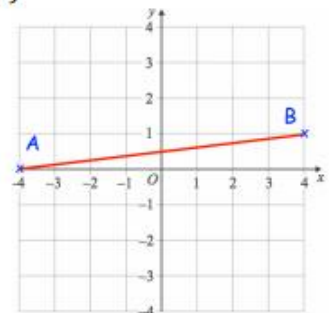

Question 3: Calculate the length of the line joining the point A and B.

(a)

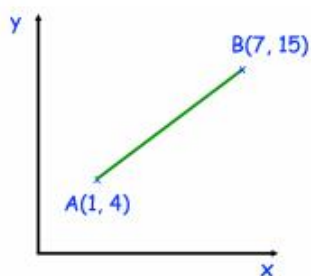

(b)

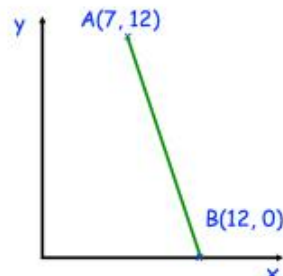

(c)

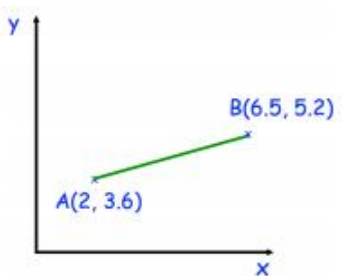

Question 4: Calculate the length of the line joining the points A and B

(a)

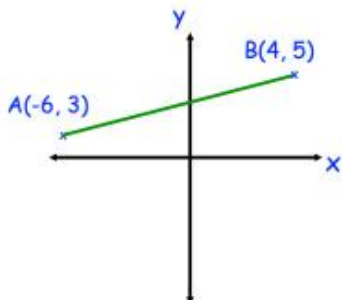

(b)

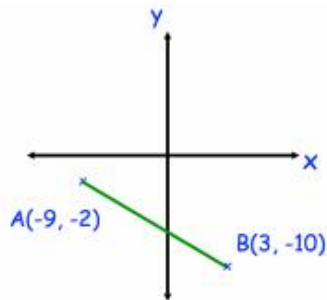

(c)

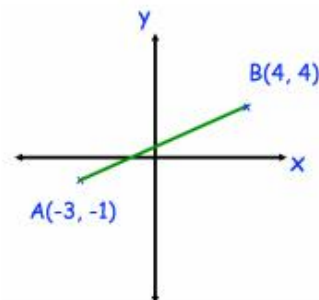

Question 5: Calculate the distance between the following pairs of coordinates

(a) (5, 1) and (9, 6)

(b) (1, 4) and (10, 10)

(c) (0, 0) and (6, 8)

(d) (2.5, 3) and (8, 0)

(e) (-6, 2) and (8, 3)

(f) (-5, -9) and (-3, 8)

(g) (-5, 7) and (-3, -2)

(h) (-9, -9) and (3, -20)

(i) (-4, 0) and (0, -4)

Apply

Question 1: Calculate the perimeter of triangle ABC.

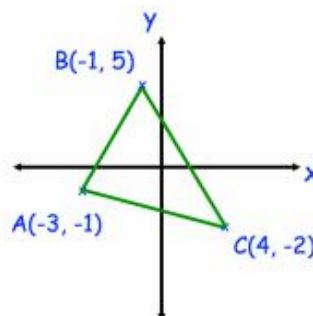

Question 2: The distance between the points (1, 2) and (16, p) is 17. Find the possible values of p.

Question 3: The distance between the points (-3, -4) and (q, 5) is 15. Find the possible values of q.

Find the lengths of the line segments joining the two points given in each question. Leave your answers in surd form where appropriate.

a) (1, 7) and (2, 8)

f) (-11, 14) and (-6, 2)

b) (1, 9) and (2, 8)

g) (5, -5) and (3, -11)

c) (2, 12) and (3, 17)

h) (5, -14) and (-3, -8)

d) (5, 8) and (9, 2)

i) (-7, -1) and (1, 5)

e) (11, 14) and (6, 2)

j) (-3, -17) and (-6, -6)

Week 1:

- LI: I can solve geometric problems on a coordinate grid

Demonstration Videos:

<https://corbettmaths.com/2013/04/15/coordinates-and-shapes/>

Tasks:

Three points are shown on a grid.
ABCD is a rectangle.

- Plot D
- Write down the coordinates of the point D

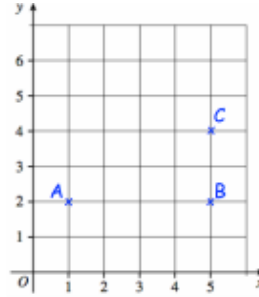

Two points are shown on a grid.
ABC is an isosceles triangle.

- Plot C
- Write down the coordinates of the point C

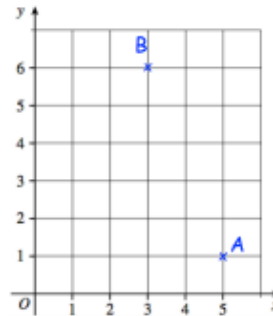

find the missing coordinates of the given shapes (i)

(1) a square

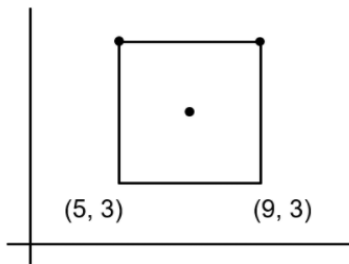

(2) a rectangle

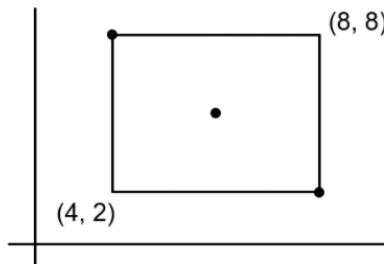

(3) a parallelogram

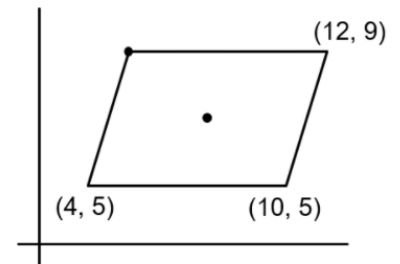

(4) a rhombus

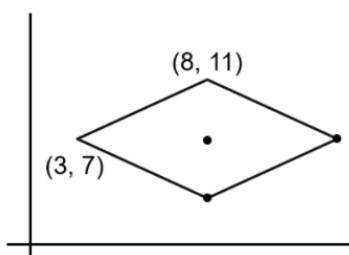

(5) an isosceles trapezium

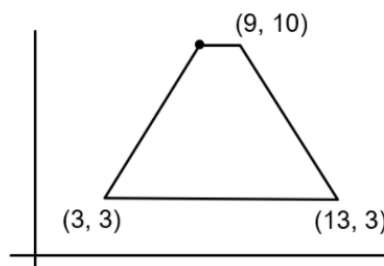

(6) an isosceles trapezium

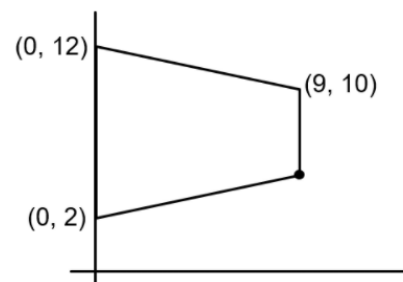

(7) a rhombus

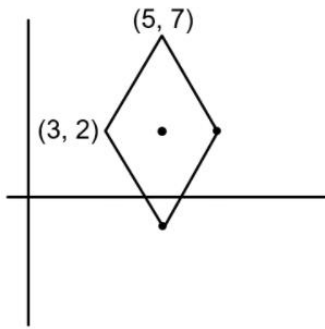

(8) a square

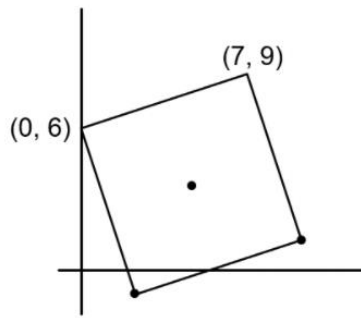

(9) a parallelogram

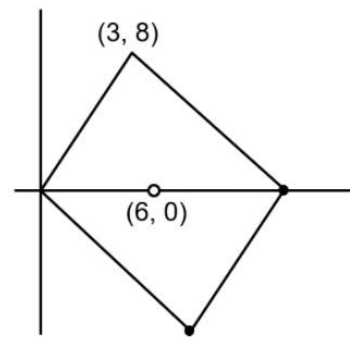

(10) a rectangle

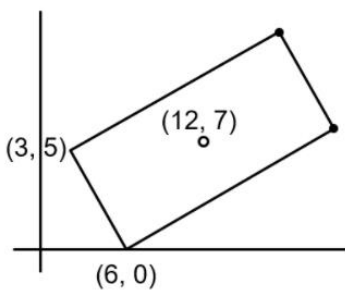

(11) a rhombus

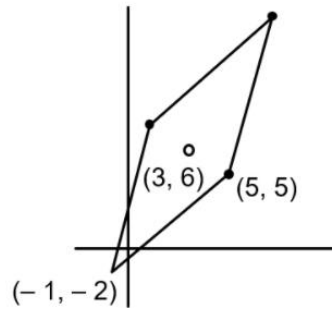

(12) a square

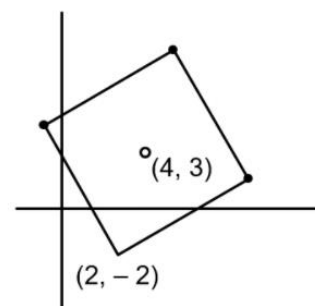

A pattern is made from four identical squares.

The sides of the squares are parallel to the axes.

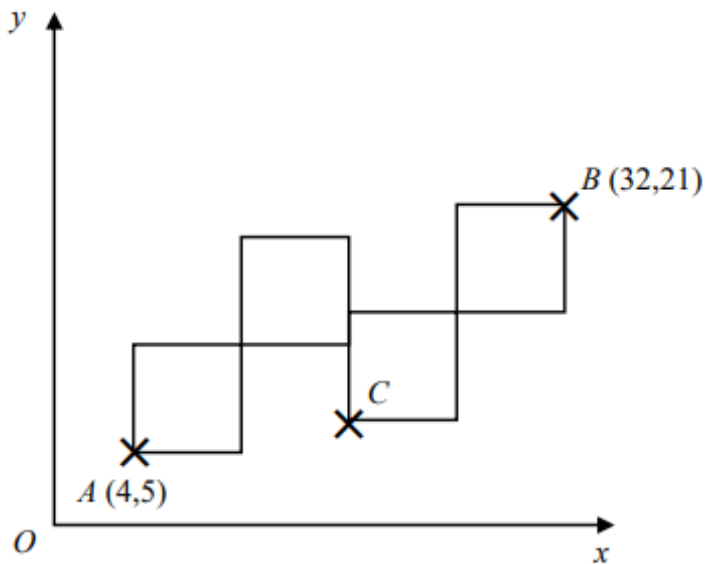

Point A has the coordinates $(4, 5)$

Point B has the coordinates $(32, 21)$

Point C is marked on the diagram.

Work out the coordinates of Point C .

Week 2:

- LI: I can find the gradient of a line segment

Demonstration Videos:

<http://corbettmaths.com/2013/05/15/gradient-of-a-line/>

<http://corbettmaths.com/2013/05/28/gradient-between-two-points/>

Tasks:

Question 1: Find the gradient of each of these lines

(a)

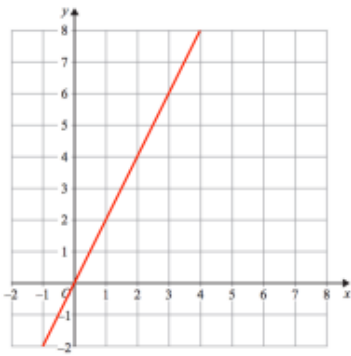

(b)

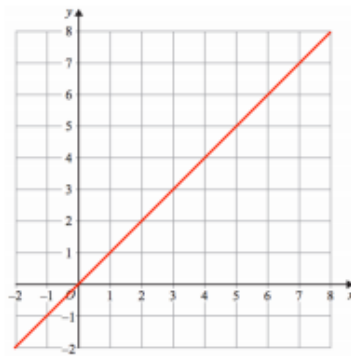

(c)

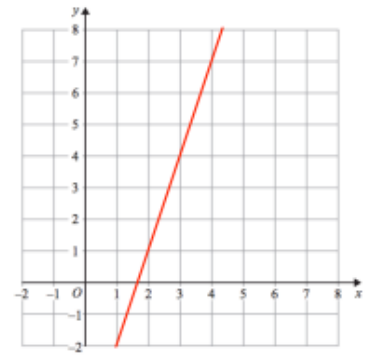

(d)

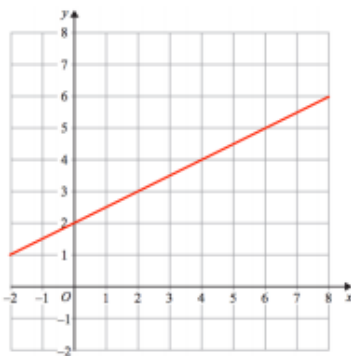

(e)

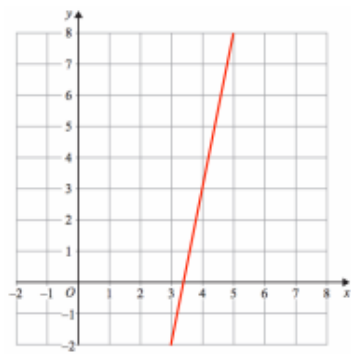

(f)

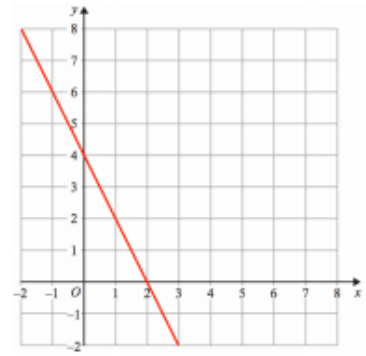

(g)

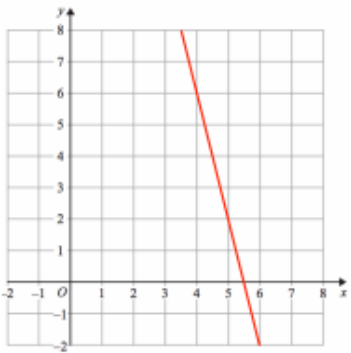

(h)

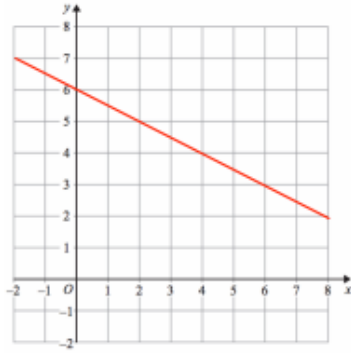

(i)

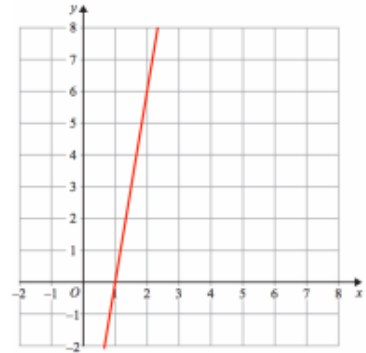

Question 2: Draw lines with the following gradients

- (a) 2 (b) 4 (c) 7 (d) -1
 (e) -3 (f) -5 (g) $\frac{1}{2}$ (h) 10

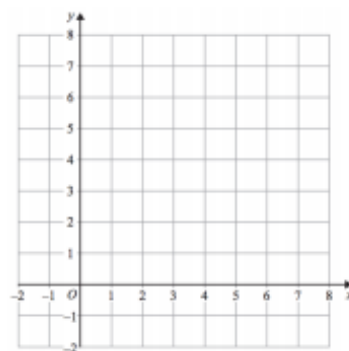

Question 6: Find the gradient of each line shown below

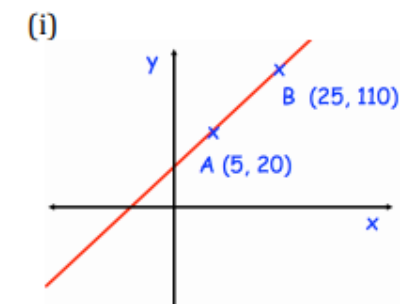
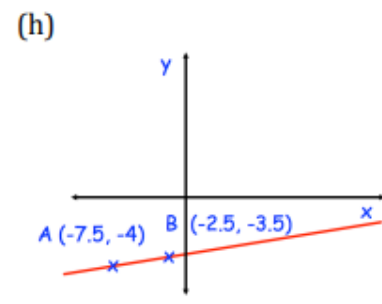
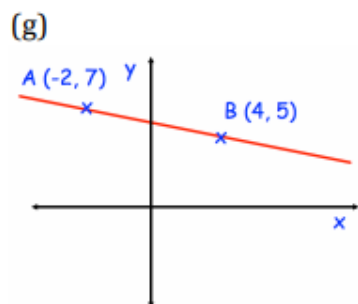
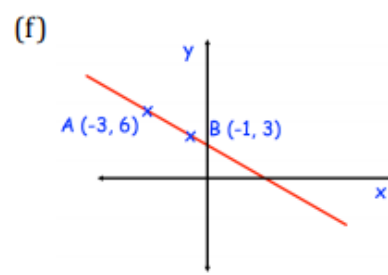
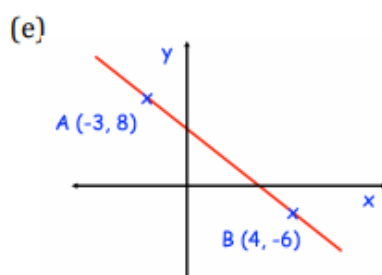
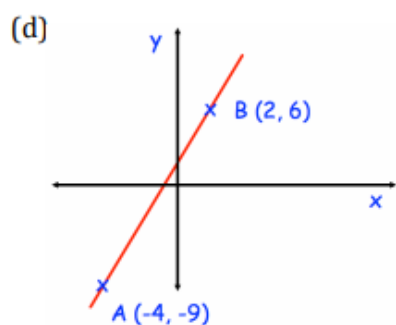
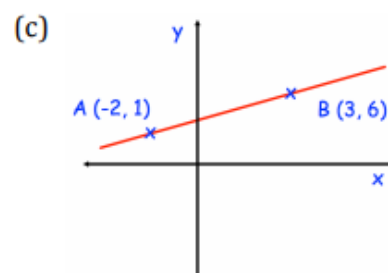
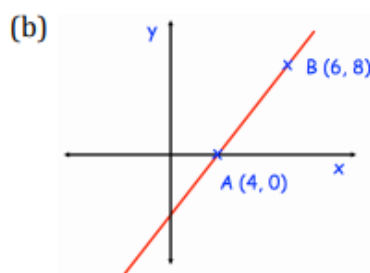
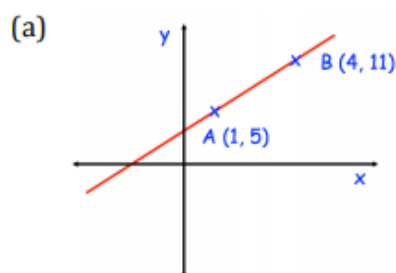

Question 7: Work out the gradient of the line passing through these pairs of points

- (a) (1, 4) and (3, 10) (b) (0, 0) and (3, 12) (c) (5, -2) and (9, 14)
 (d) (-8, 6) and (0, -2) (e) (-5, -9) and (1, 3) (f) (-7, -2) and (1, -4)
 (g) (-2, 1) and (8, -7) (h) (-2, 9) and (4, 7) (i) (-4.5, 3) and (6, -7.5)

Week 2:

- LI: I can plot a linear graph

Demonstration Videos:

<http://corbettmaths.com/2012/12/23/drawing-graphs-using-xy-tables/>

<http://corbettmaths.com/2013/04/20/drawing-graphs-using-gradient-and-intercept/>

Tasks:

Question 1: For each equation, complete the table of values and draw its graph for values of x from -1 to 3 .

(a) $y = 2x + 1$

x	-1	0	1	2	3
y	-1	1			7

(b) $y = 3x - 1$

x	-1	0	1	2	3
y	-4			5	

(c) $y = 2x - 3$

x	-1	0	1	2	3
y		-3	-1		

(d) $y = x + 4$

x	-1	0	1	2	3
y					7

(e) $y = 2x$

x	-1	0	1	2	3
y		0			6

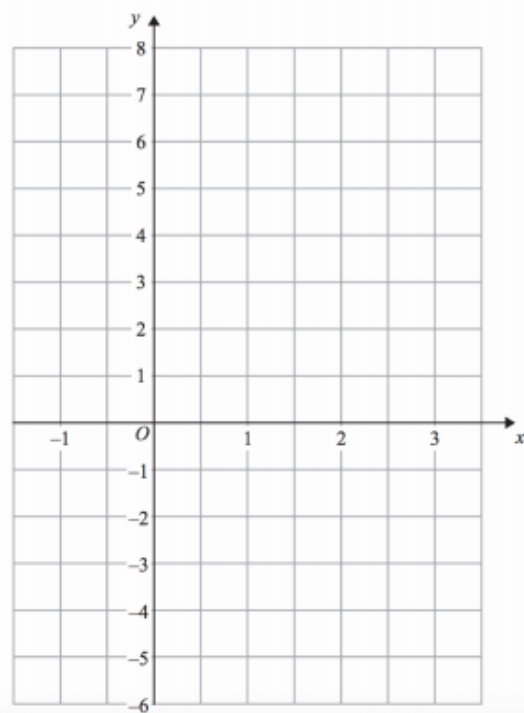

Question 2: For each equation, complete the table of values and draw its graph for values of x from -2 to 3 .

(a) $y = 2x + 4$

x	-2	-1	0	1	2	3
y						

(b) $y = 4x - 2$

x	-2	-1	0	1	2	3
y						

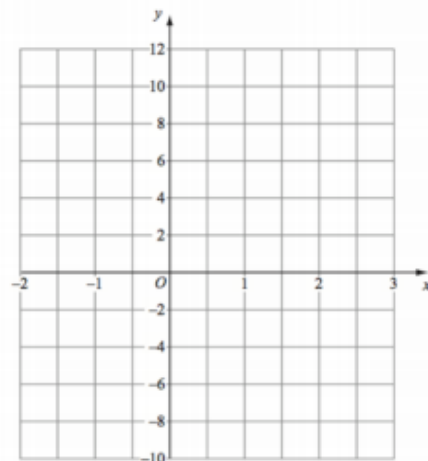

Question 3: For each equation, complete the table of values and draw its graph for values of x from -2 to 2 .

(a) $y = 3x + 3$

x	-2	-1	0	1	2
y					

(b) $y = x + 9$

x	-2	-1	0	1	2
y					

(c) $y = x - 2$

x	-2	-1	0	1	2
y					

(d) $y = x$

x	-2	-1	0	1	2
y					

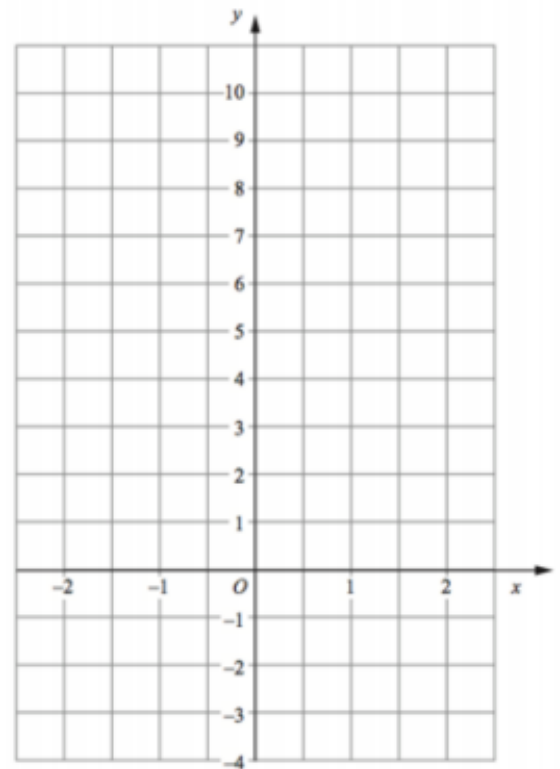

Question 4: For each equation, complete the table of values and draw its graph for values of x from -2 to 4 .

(a) $y = \frac{1}{2}x + 1$

x	-2	-1	0	1	2	3	4
y							

(b) $y = \frac{1}{4}x + 5$

x	-2	-1	0	1	2	3	4
y							

(c) $y = \frac{1}{3}x + 1$

x	-2	-1	0	1	2	3	4
y							

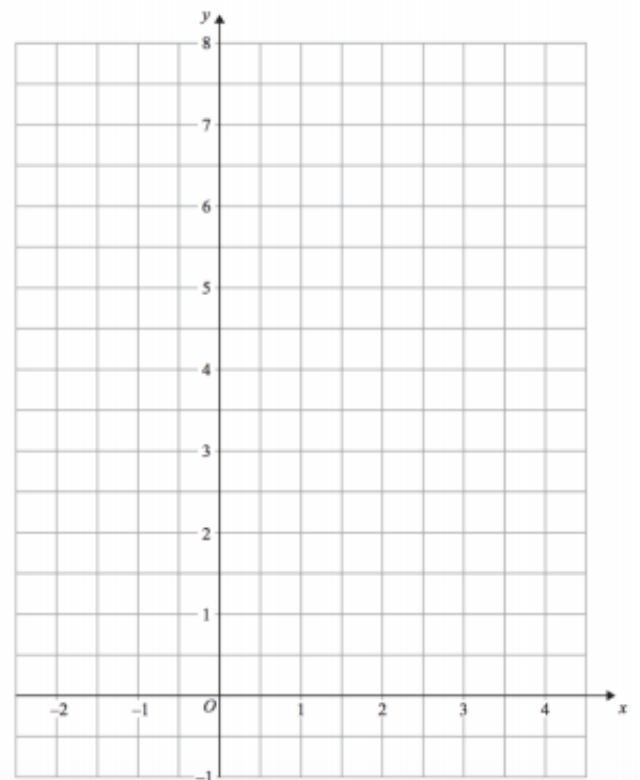

Question 5: For each equation, complete the table of values and draw its graph for values of x from -1 to 3 .

(a) $y = -2x + 5$

x	-1	0	1	2	3
y					

(b) $y = -x - 2$

x	-1	0	1	2	3
y					

(c) $y = -2x$

x	-1	0	1	2	3
y					

(d) $y = 6 - x$

x	-1	0	1	2	3
y					

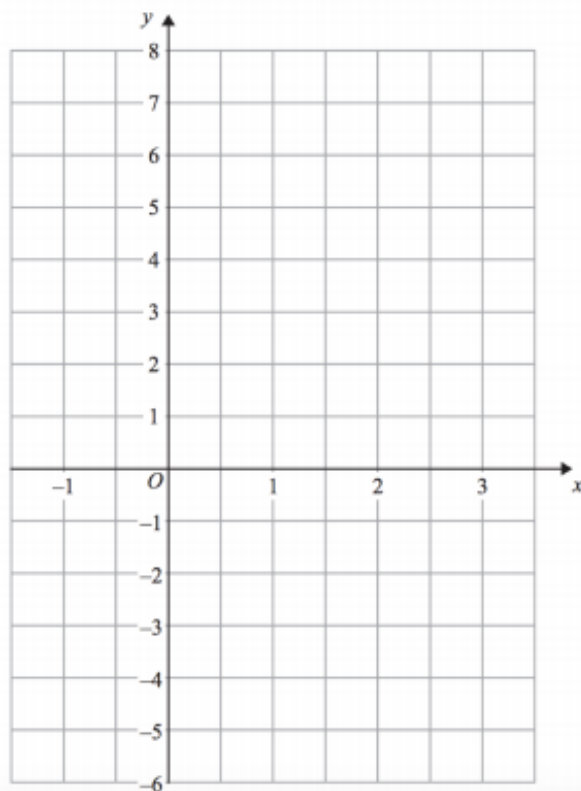

Question 6: For each equation, complete the table of values and draw its graph for values of x from -1 to 3 .

(a) $x + y = 3$

x	-1	0	1	2	3
y					

(b) $2x + y = 4$

x	-1	0	1	2	3
y					

(c) $x + 2y = -2$

x	-1	0	1	2	3
y					

(d) $2x - y = 4$

x	-1	0	1	2	3
y					

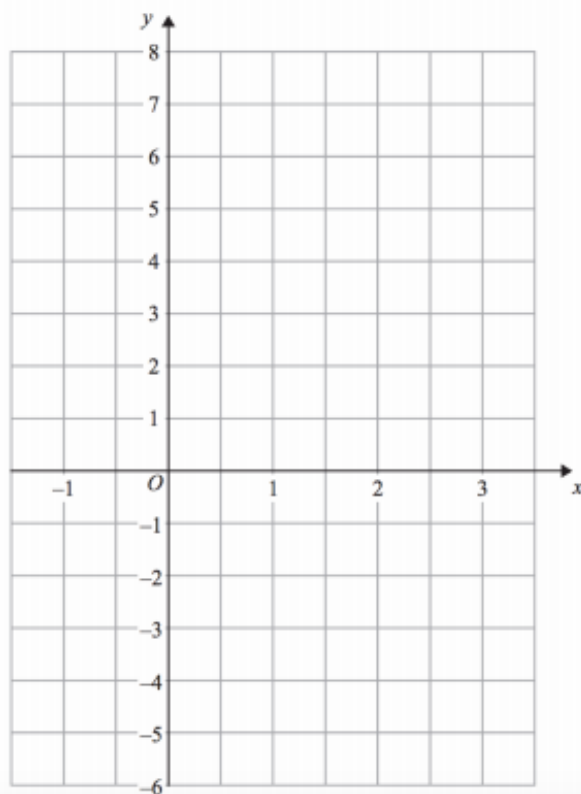

Week 2:

- LI: I can plot graphs of the form $x = a$ and $y = a$

Demonstration Videos:

<https://corbettmaths.com/wp-content/uploads/2013/02/drawing-linear-graphs-pdf.pdf>

<http://corbettmaths.com/2013/05/29/y-equals-graphs/>

Tasks:

Question 1: Draw the following graphs

(a) $x = 1$

(b) $x = 4$

(c) $x = -2$

(d) $x = 1.5$

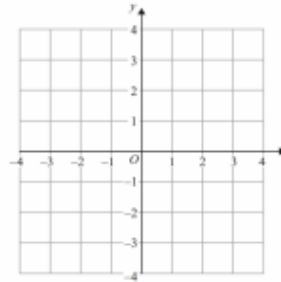

Question 2: Write down the equations of each of the lines shown below

(a)

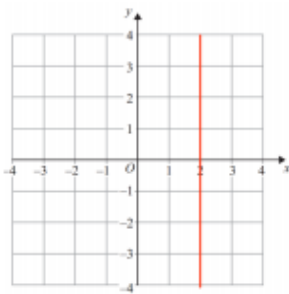

(b)

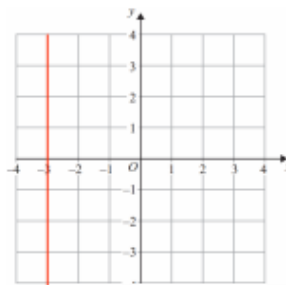

(c)

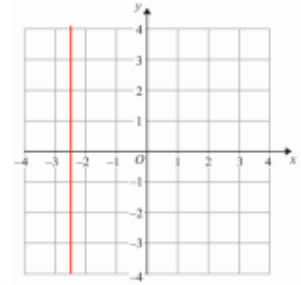

Question 3: Draw the following graphs

(a) $y = 2$

(b) $y = -1$

(c) $y = -4$

(d) $y = 0.5$

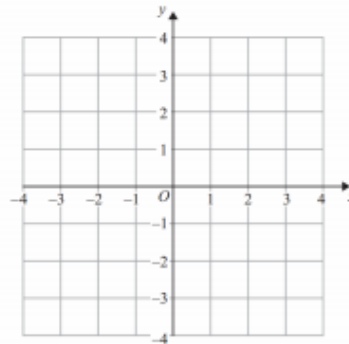

Question 4: Write down the equations of each of the lines shown below

(a)

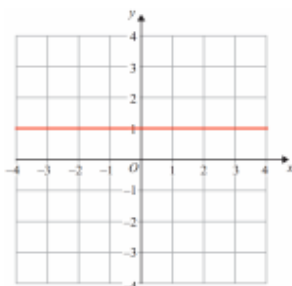

(b)

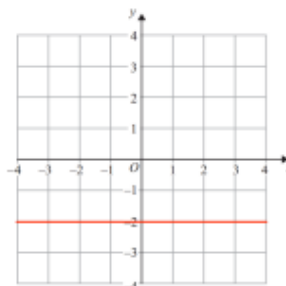

(c)

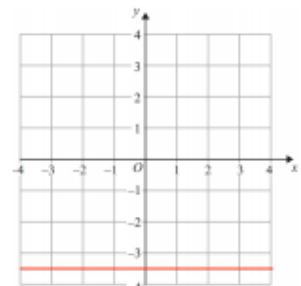

Apply

Question 1: On a copy of the grid shown

- (a) draw $y = 5$
- (b) draw $x = 4$
- (c) Write down where the two lines meet.

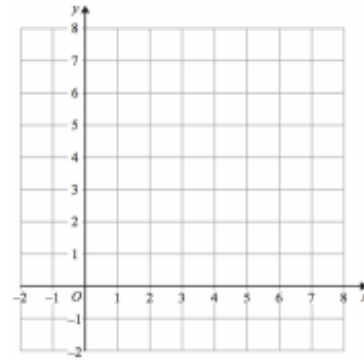

Question 2: Write down the equation of

- (a) Line 1
- (b) Line 2
- (c) Line 3

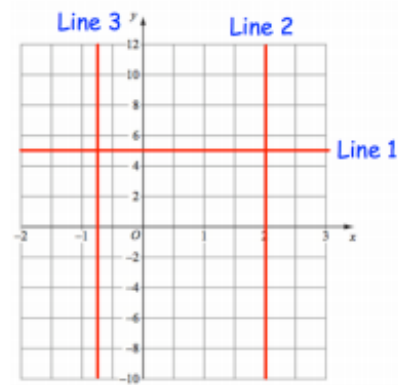

Question 3: From the box below, choose any coordinates that lie on:

- (a) $y = 2$
- (b) $x = 4$
- (c) $x = 3$
- (d) $y = -1$
- (e) the x-axis
- (f) the y-axis



Question 4: Michael has completed his homework
Can you spot any mistakes?

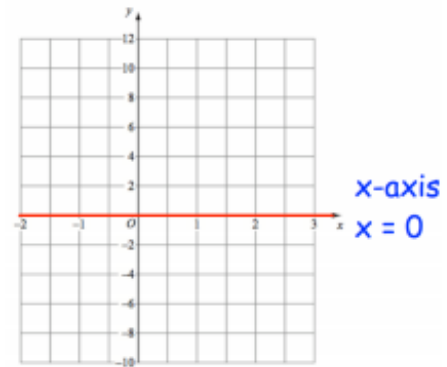



Week 3:

- LI: I can identify an equation from its graph

Demonstration Videos:

<https://corbettmaths.com/2013/05/29/finding-the-equation-of-a-straight-line/>

<https://corbettmaths.com/2013/05/29/finding-the-equation-passing-through-two-points/>

$$y = mx + c$$

gradient y-intersect

Tasks:

Question 1: Write down the gradient of each of these lines.

- (a) $y = 3x + 1$ (b) $y = 2x - 5$ (c) $y = 7x + 4$ (d) $y = 10x + 5$
(e) $y = x - 2$ (f) $y = 6x$ (g) $y = -4x + 3$ (h) $y = -3x - 7$
(i) $y = \frac{1}{2}x + 3$ (j) $y = -\frac{4}{5}x - 9$

Question 2: Write down where each of these lines cross the y-axis (y-intercept)

- (a) $y = 2x + 3$ (b) $y = 7x + 1$ (c) $y = 3x - 2$ (d) $y = x - 5$
(e) $y = 2x$ (f) $y = -4x + 6$ (g) $y = -5x - 3$ (h) $y = -3x$
(i) $y = \frac{4}{3}x + \frac{2}{5}$ (j) $y = -\frac{2}{3}x - \frac{1}{2}$

Question 3: Write down the equation of the lines below

- (a) gradient of 3 and y-intercept of 6 (b) gradient of 2 and y-intercept of -1
(c) gradient of -4 and y-intercept of 3 (d) gradient of 8 and y-intercept of 4
(e) gradient of 1 and passing through (0, 4) (f) passing through (0, -2) with gradient 4
(g) gradient of -5 and passing through the origin.

Question 5: Find the equation of each line

(a)

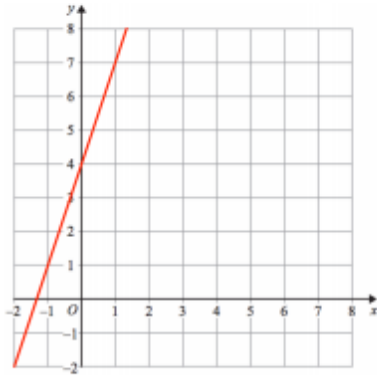

(b)

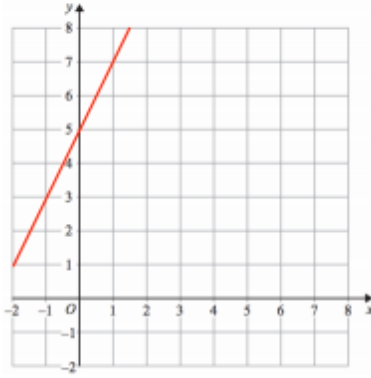

(c)

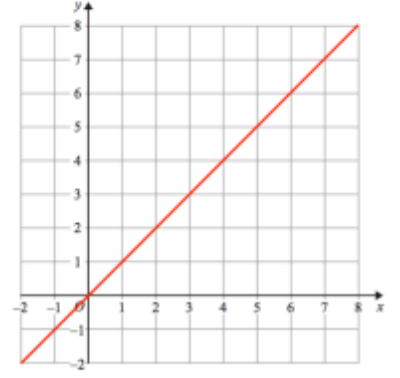

(d)

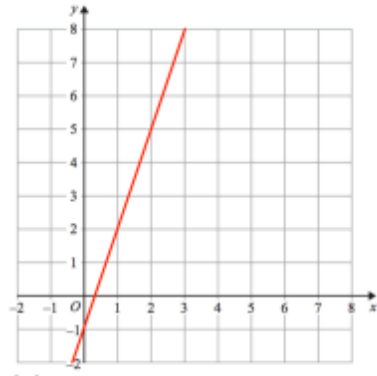

(e)

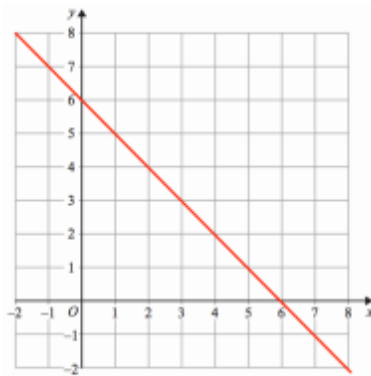

(f)

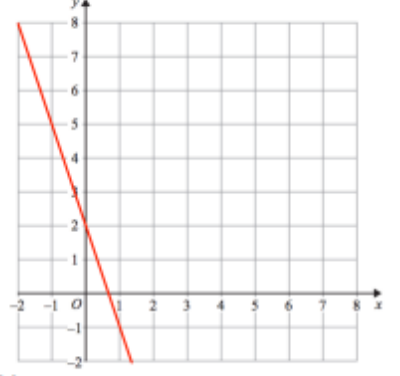

(g)

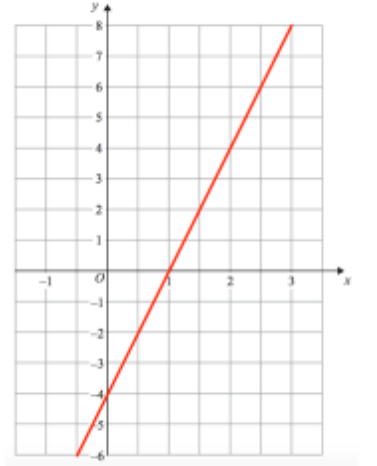

(h)

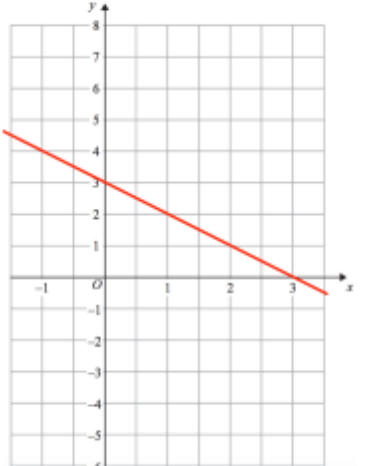

(i)

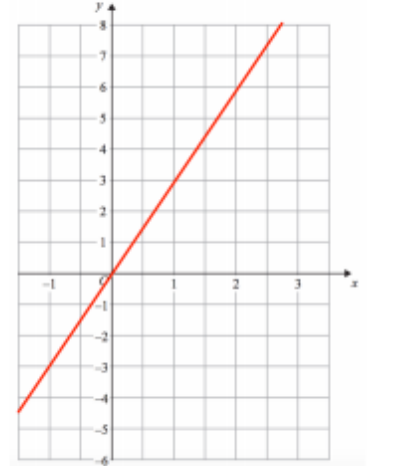

(j)

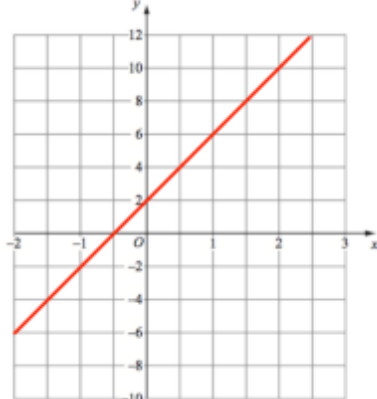

(k)

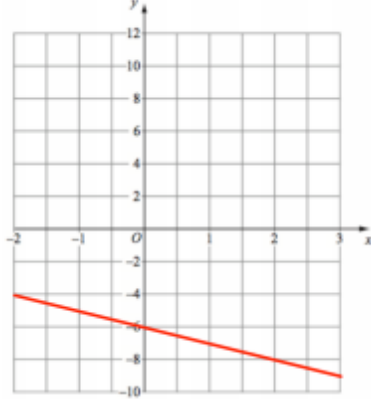

(l)

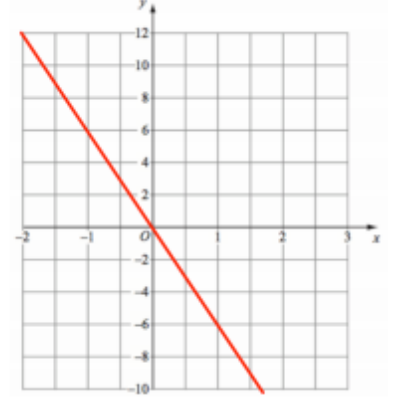

Question 6: Find the equation of each line below.

(a)

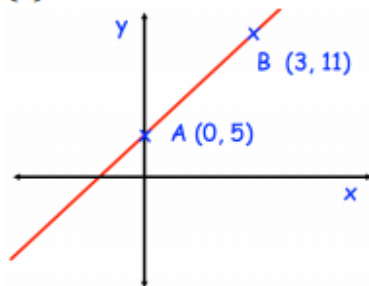

(b)

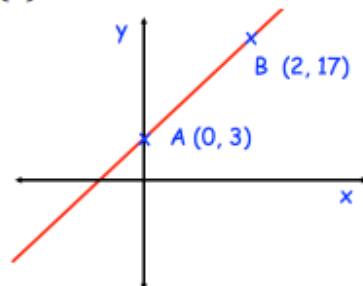

(c)

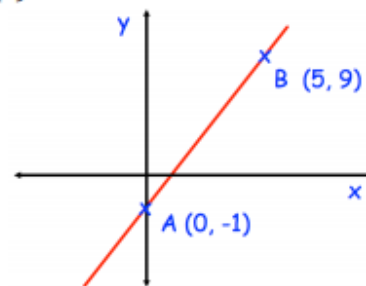

(d)

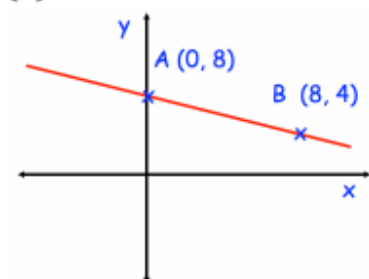

(e)

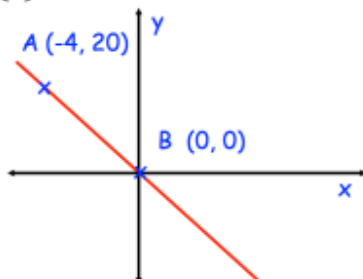

(f)

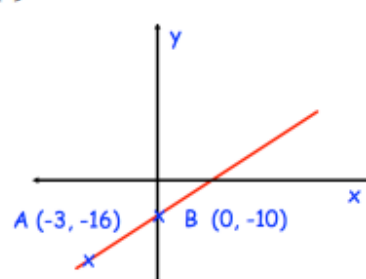

Question 7: Find the equation of the straight line that passes through the points

(a) (0, 3) and (4, 19)

(b) (0, 2) and (6, 20)

(c) (0, 0) and (1, 4)

(d) (0, -9) and (9, 0)

(e) (0, -6) and (7, 8)

(f) (-8, -10) and (0, 14)

(g) (0, 2) and (10, 7)

(h) (-4, 1) and (0, 7)

(i) (-4, 0) and (0, 18)

Question 8: Find the equation of the straight line that:

(a) has a gradient of 4 and passes through the point (1, 10)

(b) has a gradient of 2 and passes through the point (-3, 3)

(c) has a gradient of 1 and passes through the point (5, 2)

(d) has a gradient of -3 and passes through the point (-2, 8)

(e) has a gradient of -5 and passes through the point (3, -1)

(f) has a gradient of $\frac{1}{2}$ and passes through the point (4, 5)

(g) has a gradient of $\frac{2}{5}$ and passes through the point (-5, -5)

(h) has a gradient of $-\frac{2}{3}$ and passes through the point (9, 15)

Week 3:

- LI: I can plot a quadratic graph

Demonstration Videos:

<http://corbettmaths.com/2013/06/23/drawing-quadratics/>

Tasks:

Complete the table of values for $y = x^2$

x	-2	-1	0	1	2
y		1			4

Complete the table of values for $y = x^2 + 3$

x	-2	-1	0	1	2
y	7		3	4	

Complete the table of values for $y = 2x^2 - x - 3$

x	-2	-1	0	1	2	3
y						

Complete the table of values for $y = 8 - x^2$

x	-2	-1	0	1	2	3
y						

Complete the table of values for $y = x^2 + x - 6$

x	-3	-2	-1	0	1	2	3
y				-6	0		

(2)

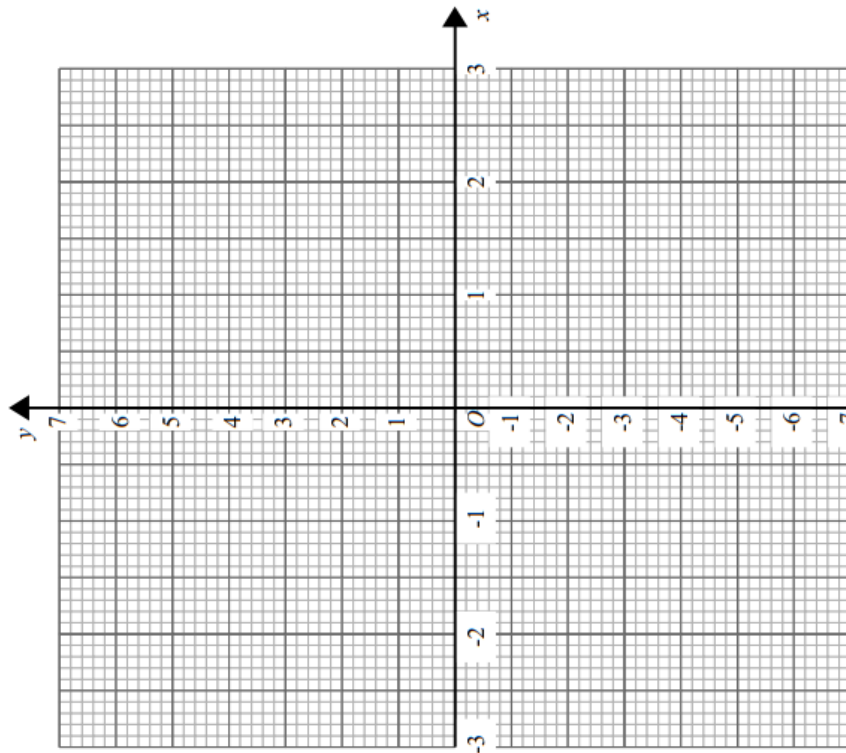

(2)

(a) On the grid draw the graph of $y = x^2 + x - 6$ for values of x from -3 to 3



22 Complete the table of values for $y = 7x - x^2$

x	-1	0	1	2	3	4	5
y							

(2)

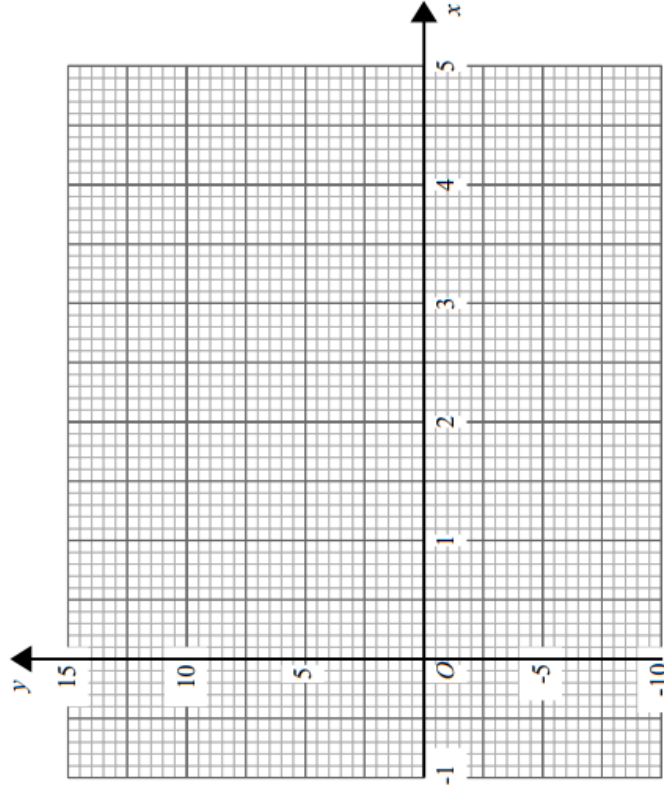

(a) On the grid draw the graph of $y = 7x - x^2$ for values of x from -1 to 5

Complete the table of values for $y = x^2 - 3x - 1$

x	-2	-1	0	1	2	3	4
y							

(2)

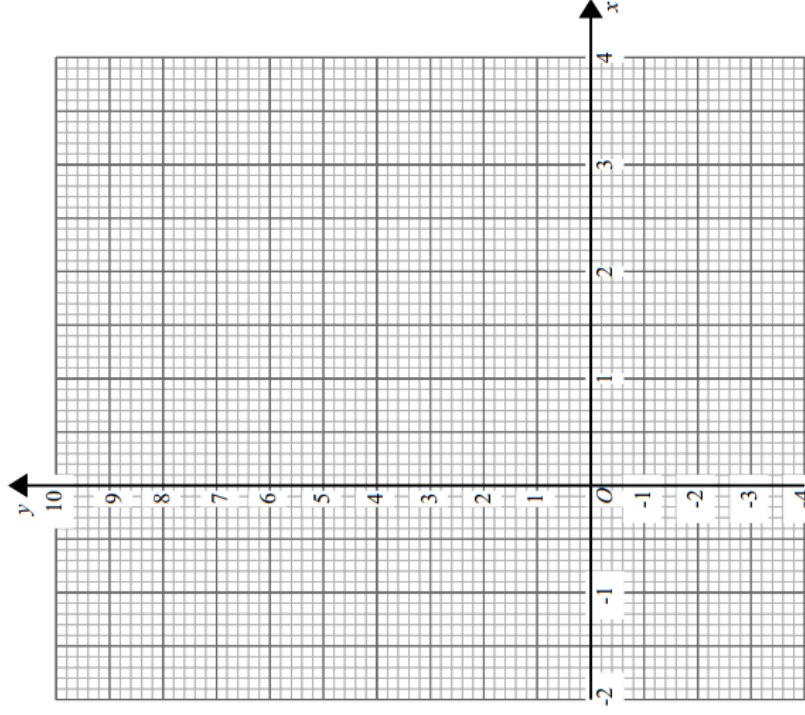

(a) On the grid draw the graph of $y = x^2 - 3x - 1$ for values of x from -2 to 4

(2)

Week 3:

- LI: I can find solutions to a quadratic equation using a graph

Demonstration Videos:

<https://corbettmaths.com/2017/12/13/solving-quadratics-graphically/>

Tasks:

Question 1: Using the graphs below, solve each equation.

$$y = x^2 - x - 12$$

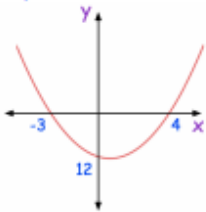

(a) Solve $x^2 - x - 12 = 0$

$$y = x^2 - 4x + 3$$

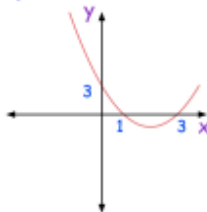

(b) Solve $x^2 - 4x + 3 = 0$

$$y = x^2 + 7x$$

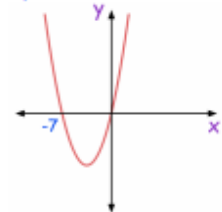

(c) Solve $x^2 + 7x = 0$

Question 2: Using the graphs below, solve each equation

$$y = 2x^2 - 3x - 2$$

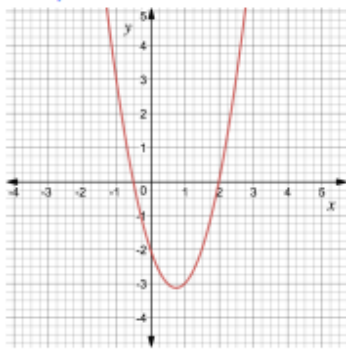

(a) Solve $2x^2 - 3x - 2 = 0$

$$y = 2x^2 - 13x + 15$$

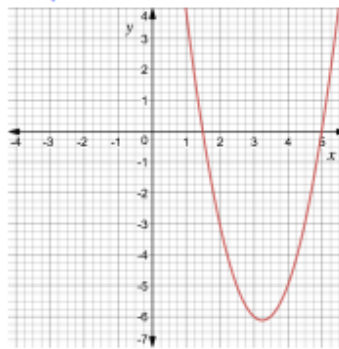

(b) Solve $2x^2 - 13x + 15 = 0$

$$y = 4x^2 + 11x + 7$$

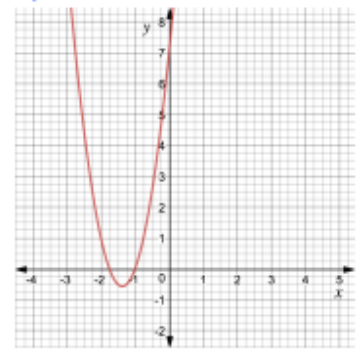

(c) Solve $4x^2 + 11x + 7 = 0$

Question 3: Using the graphs, find estimates of the solutions to the following equations

$$y = x^2 - 7x + 5$$

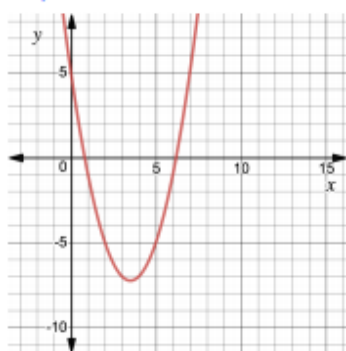

(a) $x^2 - 7x + 5 = 0$

$$y = x^2 + x - 1$$

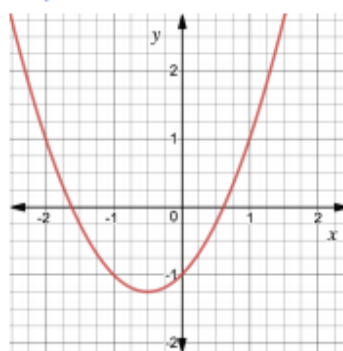

(b) $x^2 + x - 1 = 0$

$$y = x^2 - 2x - 13$$

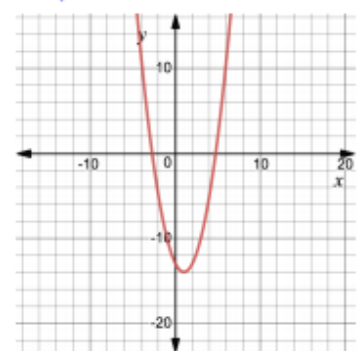

(c) $x^2 - 2x - 13 = 0$

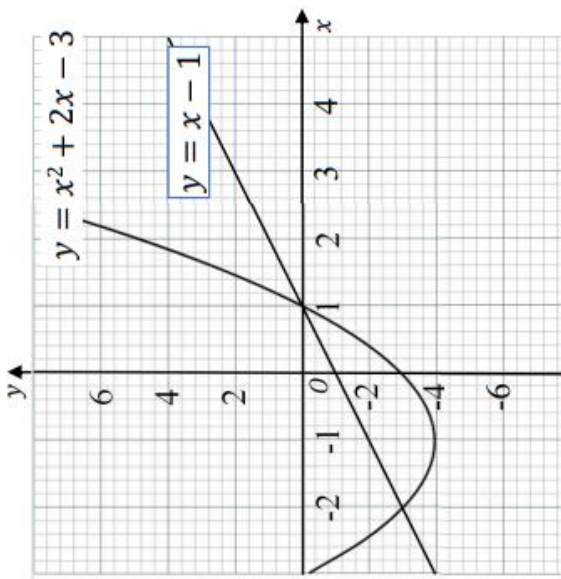

Use the graph to solve: $x^2 + x - 2 = 0$

- 1) Subtract the equation to solve from the given graph.

$$y = x^2 + 2x - 3$$

$$- \quad 0 = x^2 + x - 2$$

$$y = 0 + x - 1$$

- 2) Plot the graph. $y = x - 1$

- 3) Find the x -coordinates where the lines intersect.

The x -coordinates are the solutions to the equation.

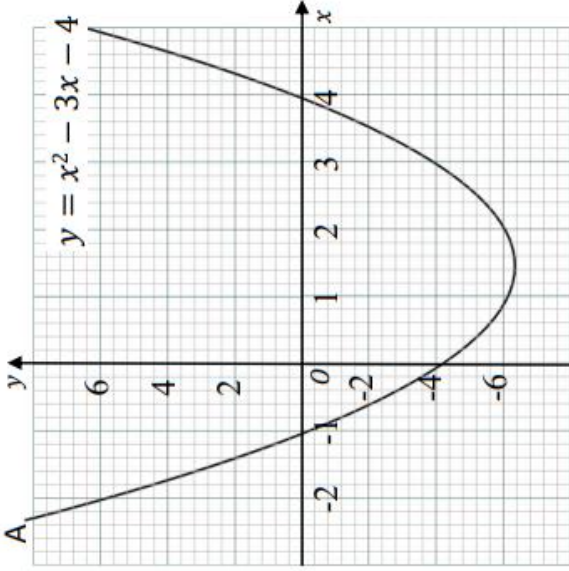

Use the graph to solve: $x^2 - 4x - 2 = 0$

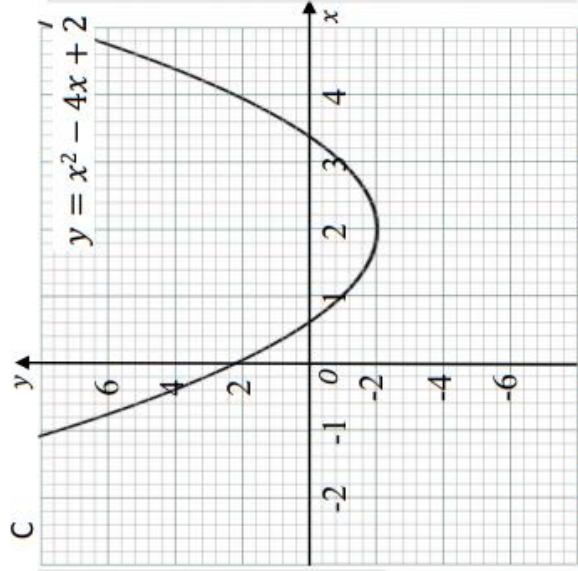

Use the graph to solve: $x^2 - 4x - 1 = 0$

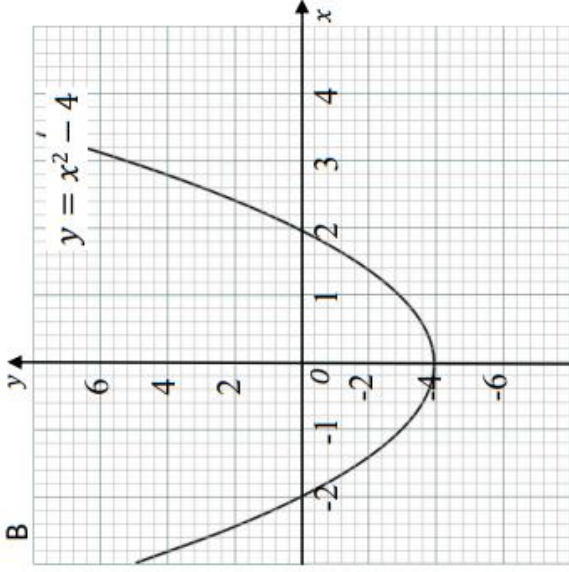

Use the graph to solve: $x^2 - x - 5 = 0$

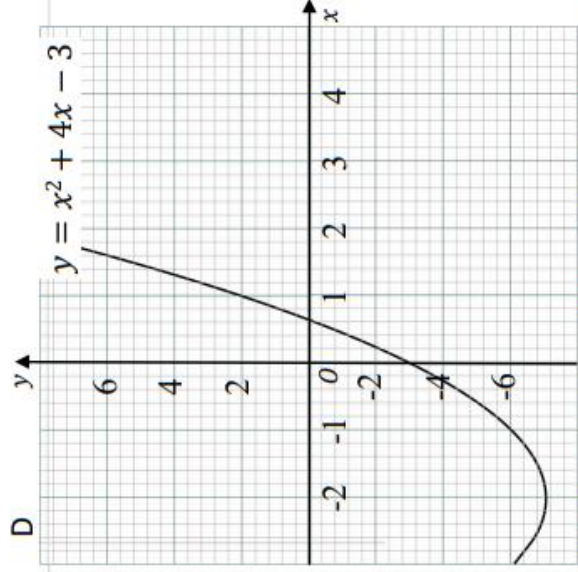

Use the graph to solve: $x^2 + 2x - 1 = 0$



Week 4:

- LI: I can plot a cubic graph

Demonstration Videos:

<https://corbettmaths.com/2016/08/07/cubic-graphs/>

Tasks:

Complete the table of values for $y = x^3 + x - 2$

x	-2	-1	0	1	2
y					

Complete the table of values for $y = x^3 + 3x$

x	-2	-1	0	1	2
y					

1. (a) Complete the table of values for $y = x^3 - 2x + 3$

x	-2	-1	0	1	2
y					

- (b) On the grid, draw the graph of $y = x^3 - 2x + 3$ for the values of x
 $-2 \leq x \leq 2$

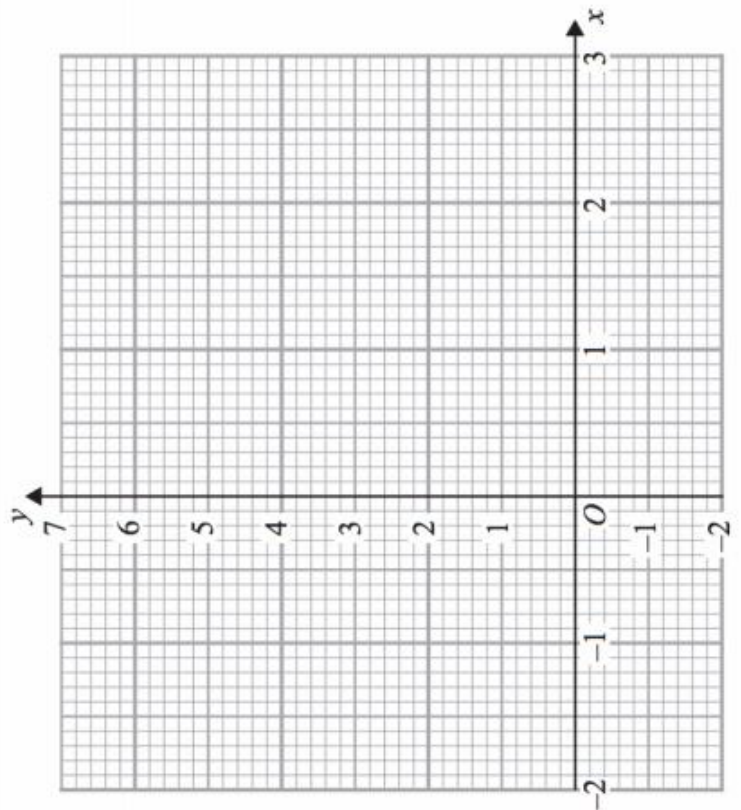



26 3. (a) Complete this table of values for $y = -x^3 - x + 2$

x	-2	-1	0	1	2
y					

2. (a) Complete the table of values for $y = x^3 + 2x^2 - 1$

x	-3	-2	-1	0	1	2
y						

(b) On the grid, draw the graph of $y = -x^3 - x + 2$ for the values of x $-2 \leq x \leq 2$

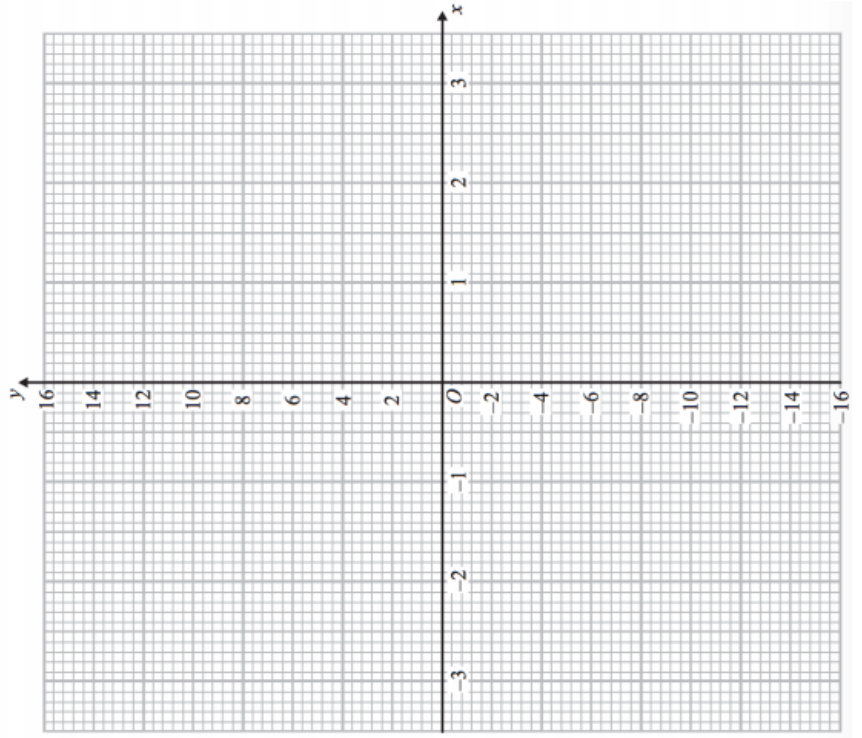

(b) On the grid, draw the graph of $y = x^3 + 2x^2 - 1$ for the values of x $-3 \leq x \leq 2$

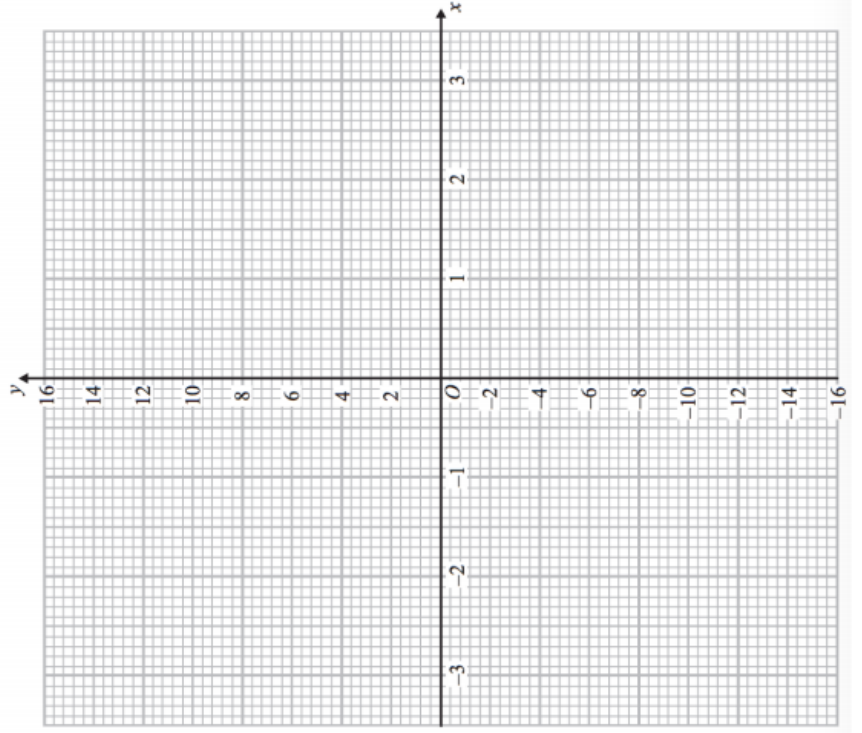



Week 4:

- LI: I can plot a reciprocal graph

Demonstration Videos:

<http://corbettmaths.com/2013/10/24/reciprocal-graphs/>

Tasks:

1. (a) Complete the table of value for $y = \frac{4}{x}$

x	0.5	1	2	4	8	10
y						

2. Complete the table of values for $y = \frac{5}{x}$

x	0.5	1	2	4	8	10
y						

3. (a) Complete the table of values for $y = \frac{2}{x}$

x	-5	-2	-1	-0.5	0.5	1	2	5
y								

(2)

- (b) On the grid, draw the graph of $y = \frac{2}{x}$ for $0.5 \leq x \leq 10$

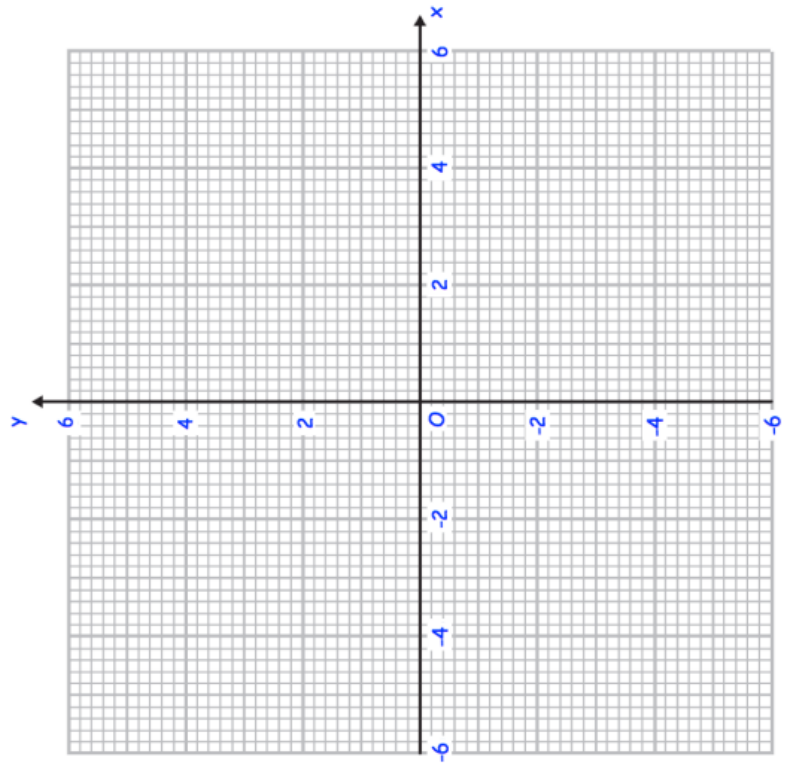



(a) Complete the table of values for $y = x + \frac{1}{x}$

x	0.2	0.4	0.6	0.8	1	2	4	5
y								

(a) Complete the table of values for $y = \frac{6}{x}$

x	0.5	1	1.5	2	3	4	5	6
y								

(b) On the grid, draw the graph of $y = x + \frac{1}{x}$

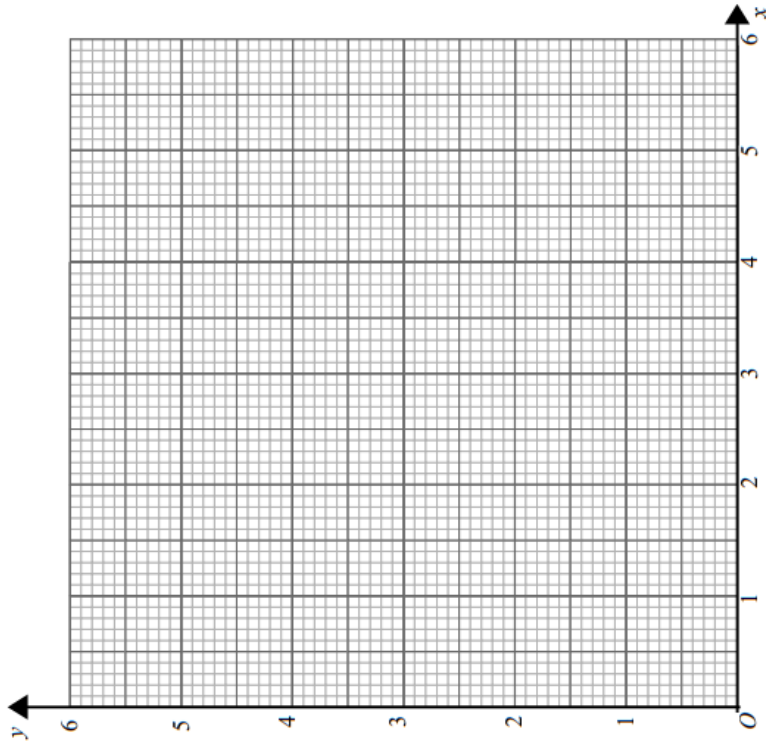

(b) On the grid, draw the graph of $y = \frac{6}{x}$

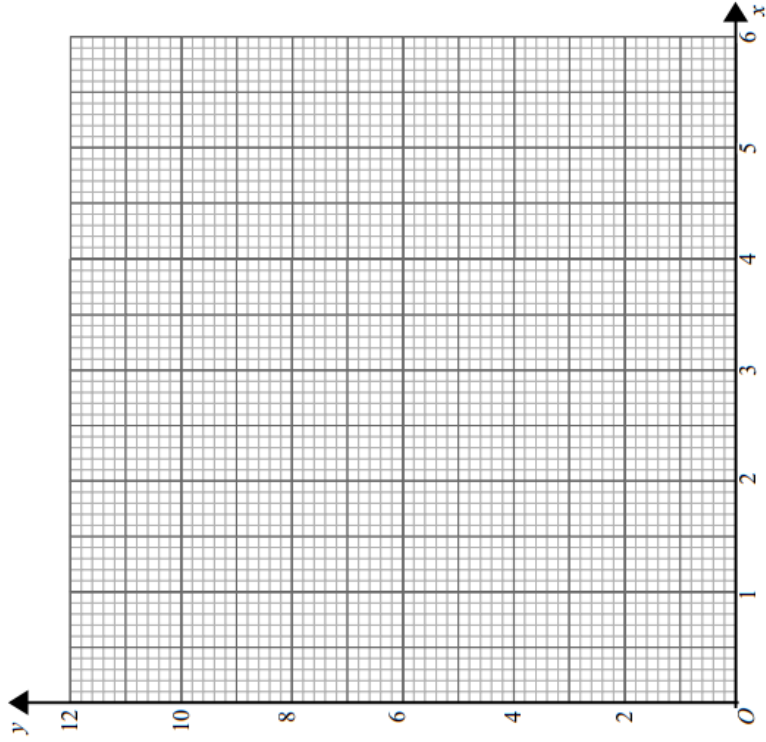

Week 4:

- LI: I can perform translations and rotations on a coordinate grid

Demonstration Videos:

<http://corbettmaths.com/2012/08/10/transformations-translations/>

<http://corbettmaths.com/2013/05/19/rotations/>

Tasks:

Question 1: Translate each of the shapes below as instructed.

(a)

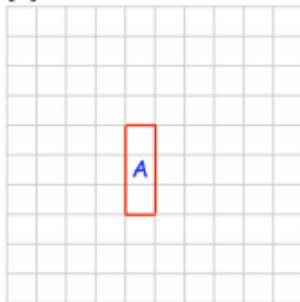

Translate A by $\begin{pmatrix} 3 \\ 1 \end{pmatrix}$

(b)

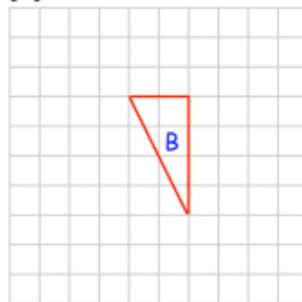

Translate B by $\begin{pmatrix} 2 \\ -2 \end{pmatrix}$

(c)

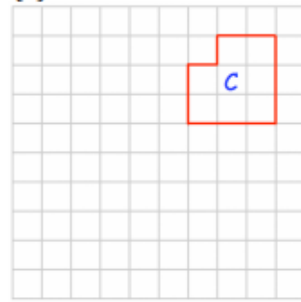

Translate C by $\begin{pmatrix} 0 \\ -5 \end{pmatrix}$

(d)

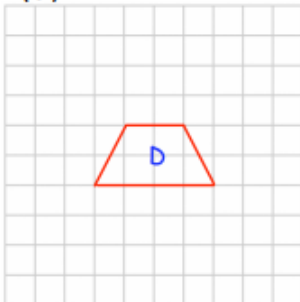

Translate D by $\begin{pmatrix} -3 \\ 3 \end{pmatrix}$

(e)

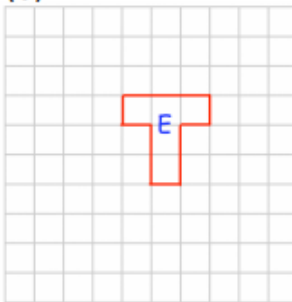

Translate E by $\begin{pmatrix} -2 \\ -4 \end{pmatrix}$

(f)

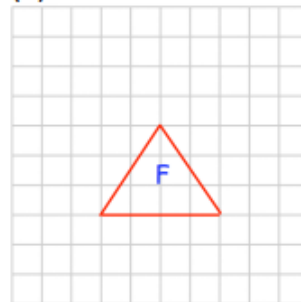

Translate F by $\begin{pmatrix} 1.5 \\ 0 \end{pmatrix}$

Question 2: Describe fully each translation that takes shape A to shape B

(a)

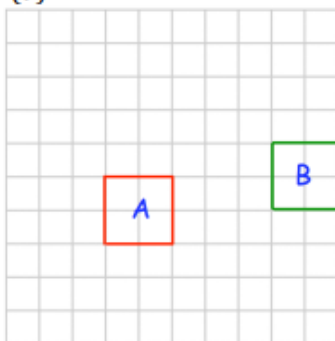

(b)

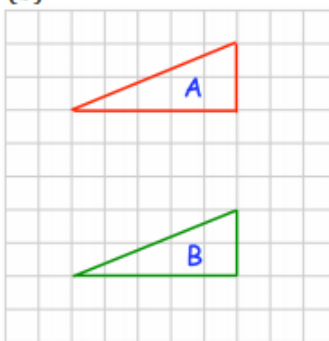

(c)

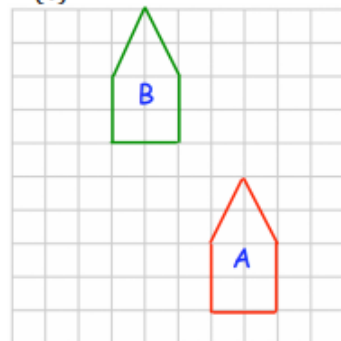

Question 1: Rotate each of the shapes below as instructed, using P as the centre of rotation.

(a)

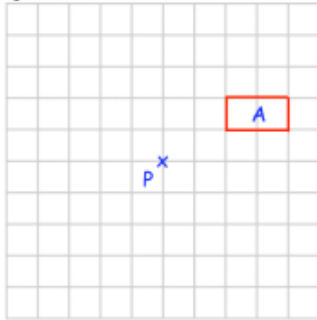

rotate 90° clockwise about P

(b)

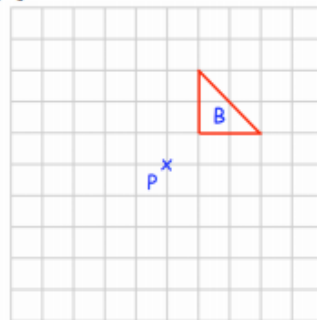

rotate 90° anticlockwise about P

(c)

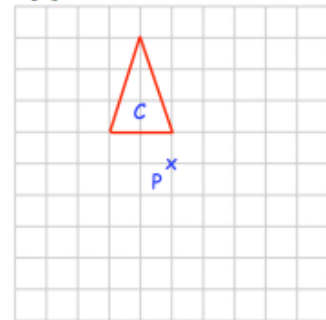

rotate 90° clockwise about P

(d)

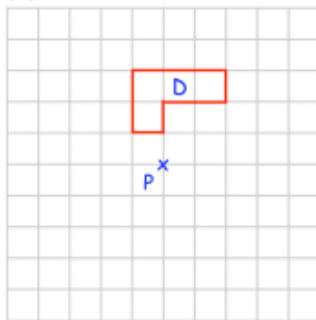

rotate 180° about P

(e)

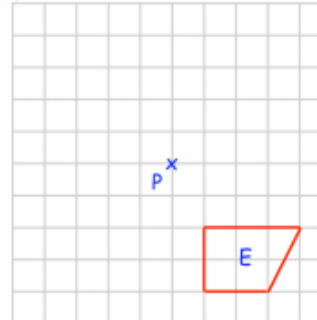

rotate 90° anticlockwise about P

(f)

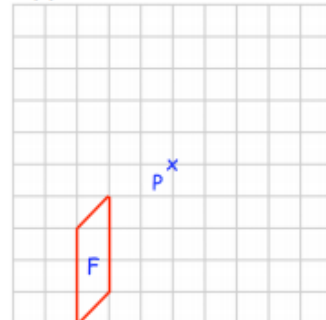

rotate 180° about P

(g)

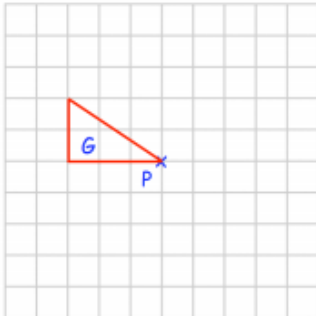

rotate 90° clockwise about P

(h)

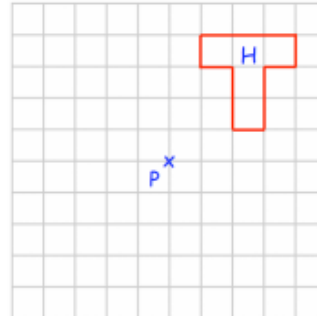

rotate 270° clockwise about P

(i)

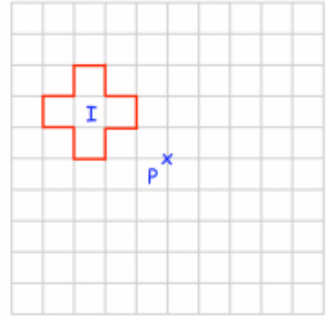

rotate 270° anticlockwise about P

Question 3: Rotate each of the shapes below as instructed.

(a)

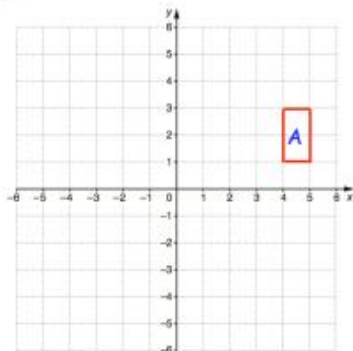

rotate 90° anticlockwise about $(0, 1)$

(b)

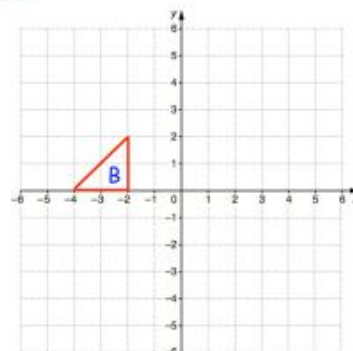

rotate 90° clockwise about $(-1, -2)$

(c)

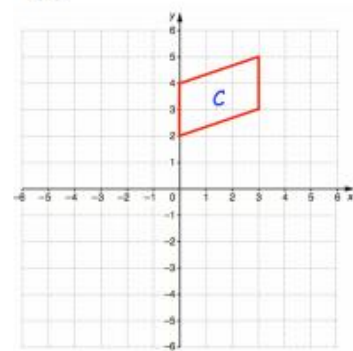

rotate 180° about $(1, 1)$

(d)

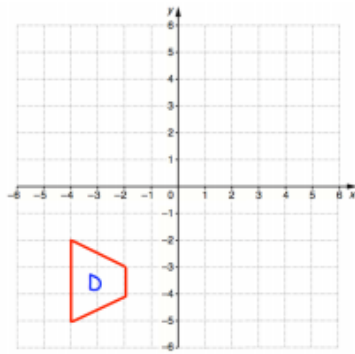

rotate 90° anticlockwise about $(-4, 0)$

(e)

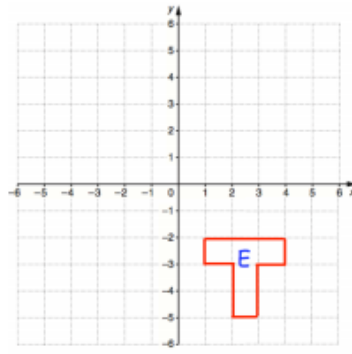

rotate 180° about $(-1, 0)$

(f)

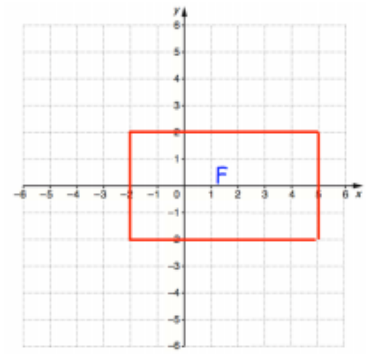

rotate 90° clockwise about $(-1, 2)$

Question 4: Describe fully the single transformation that takes shape A to shape B.

(a)

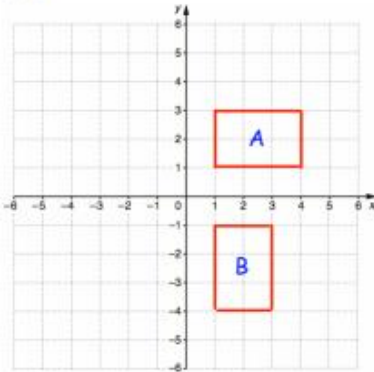

(b)

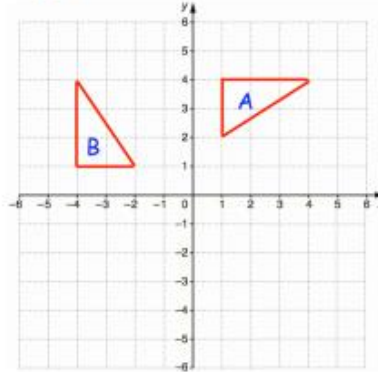

(c)

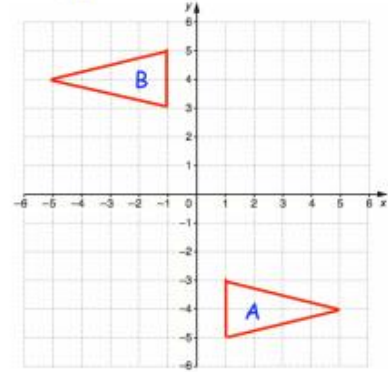

(d)

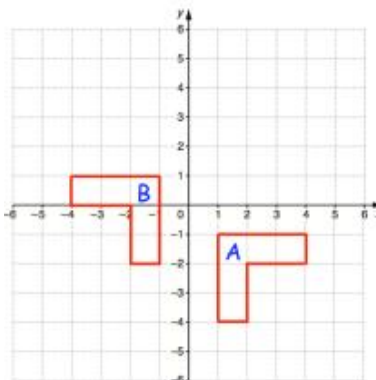

(e)

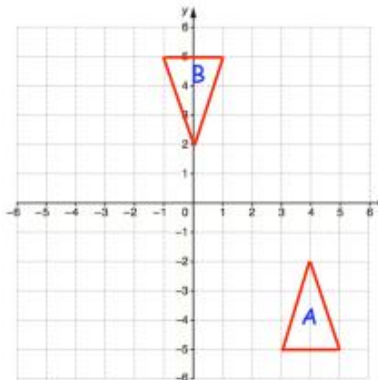

(f)

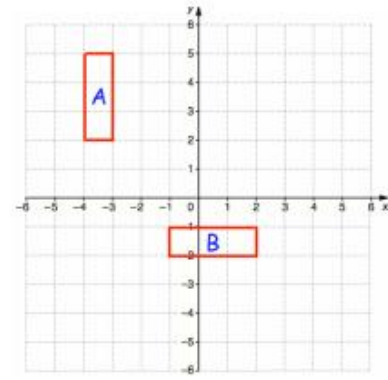

Week 5:

- LI: I can perform reflections on a coordinate grid

Demonstration Videos:

<http://corbettmaths.com/2012/08/19/reflections/>

Tasks:

Question 1: Reflect each shape in the mirror line given

(a)

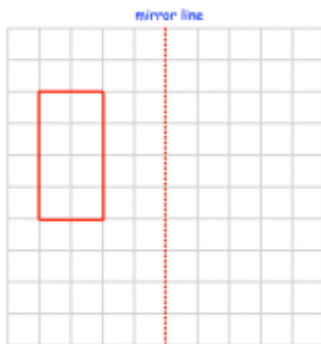

(b)

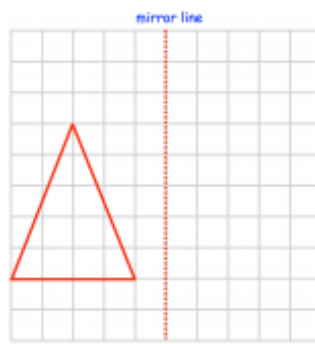

(c)

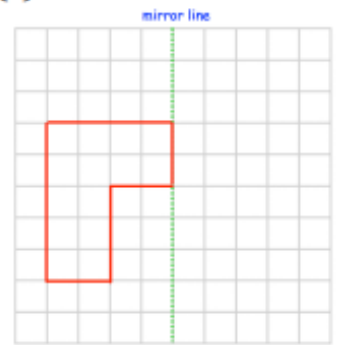

(d)

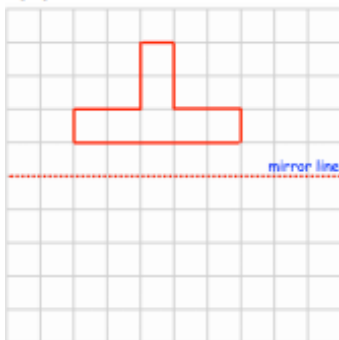

(e)

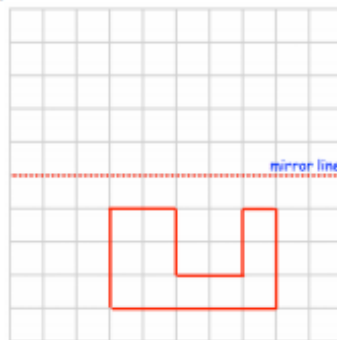

(f)

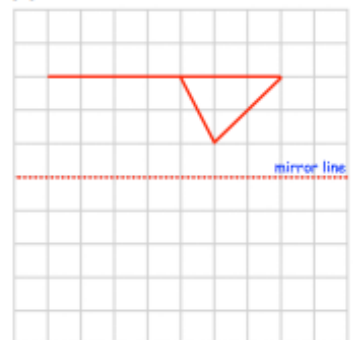

(g)

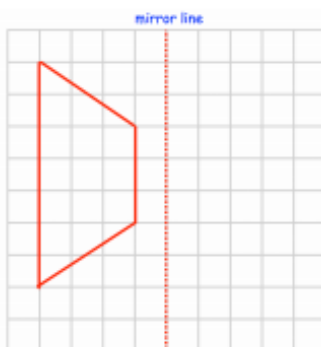

(h)

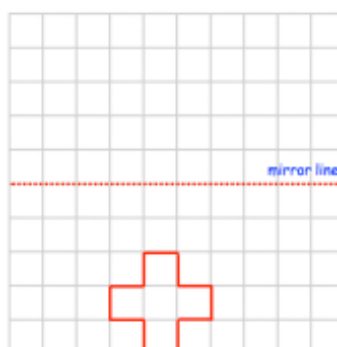

(i)

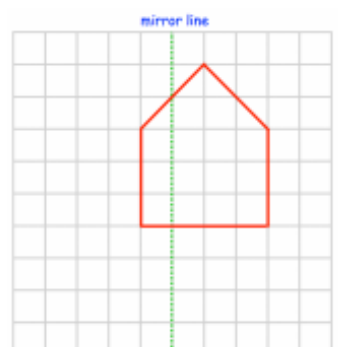

Question 2: Reflect each shape in the mirror line given

(a)



(b)



(c)

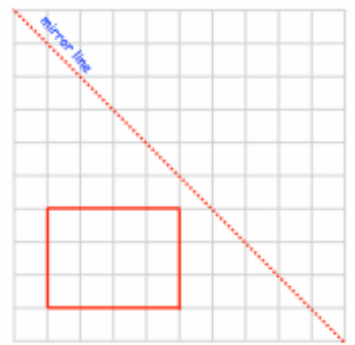

(d)



(e)

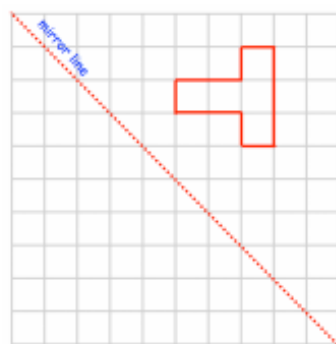

(f)



Question 3: Find the mirror line for each of the reflections below.

(a)

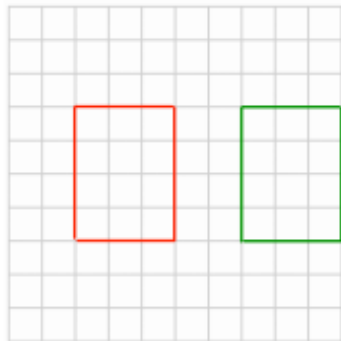

(b)

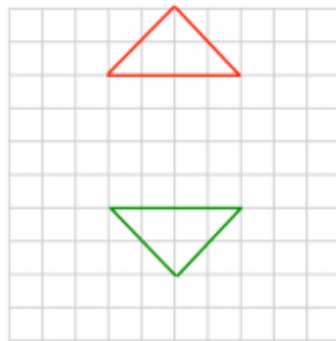

(c)

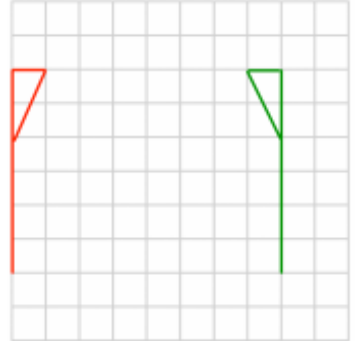

(d)

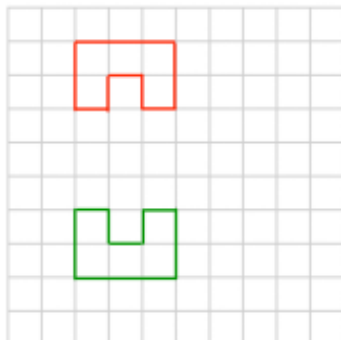

(e)

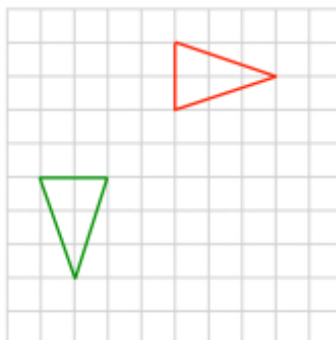

(f)

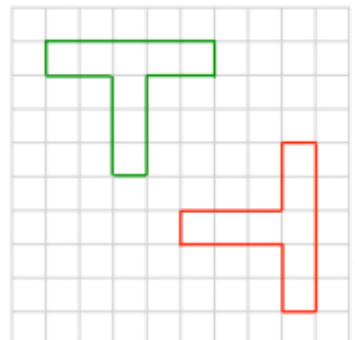

Question 6:

(a)

Reflect shape A in the line $y = x$

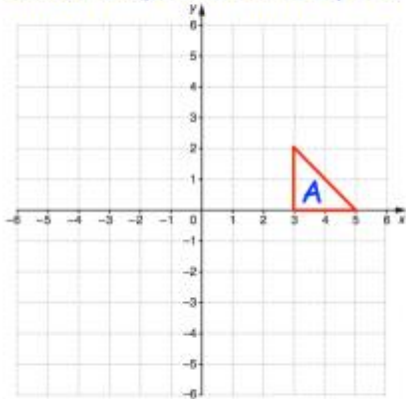

(b)

Reflect shape B in the line $y = -x$

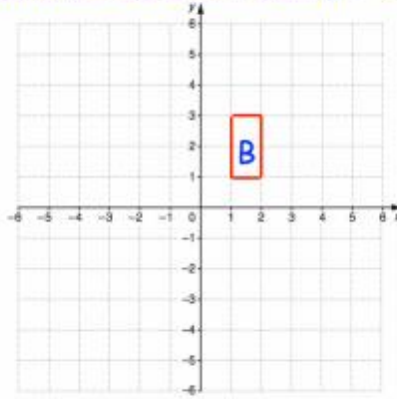

(c)

Reflect shape C in the line $y = x$

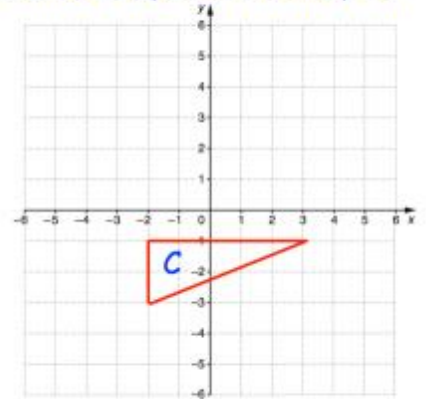

Question 7: Describe fully the single transformation that takes shape A to shape B.

(a)

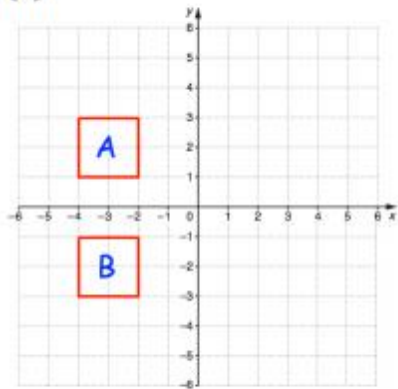

(b)

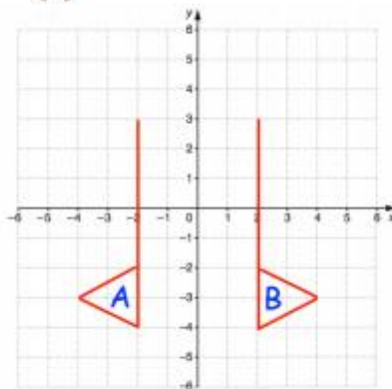

(c)

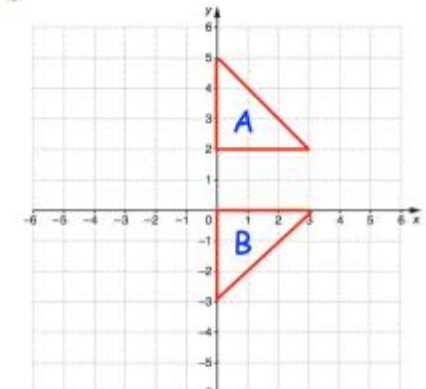

(d)

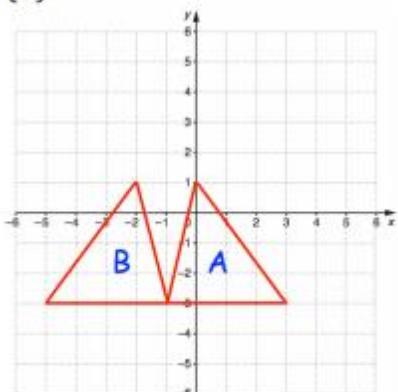

(e)

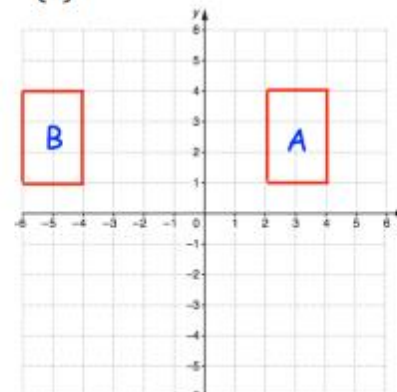

(f)

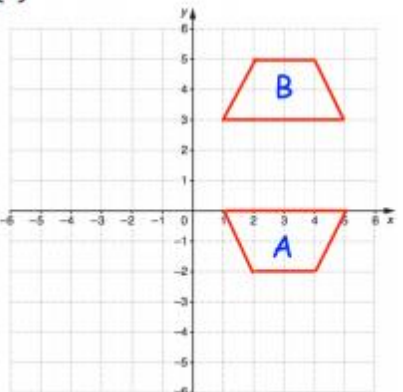

Week 5:

- LI: I can enlarge a shape on a coordinate grid

Demonstration Videos:

<http://corbettmaths.com/2012/08/19/enlargements/>

<http://corbettmaths.com/2013/05/12/describing-enlargements/>

<http://corbettmaths.com/2013/03/29/finding-the-centre-of-enlargement/>

Tasks:

Question 1: Copy these shapes and then enlarge by the scale factor given.

(a)

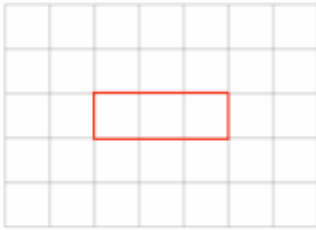

Enlarge by scale factor 3

(b)

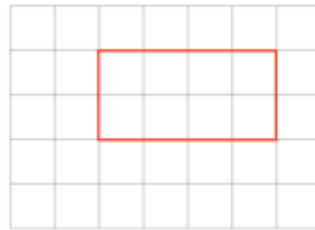

Enlarge by scale factor 2

(c)

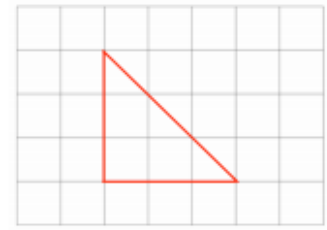

Enlarge by scale factor 3

(d)

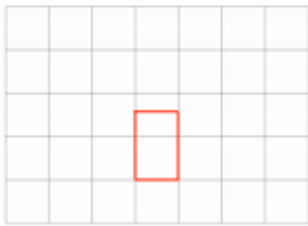

Enlarge by scale factor 4

(e)

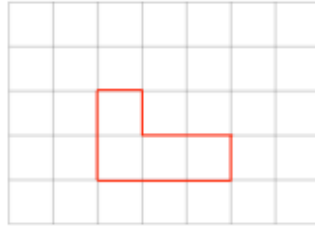

Enlarge by scale factor 2

(f)

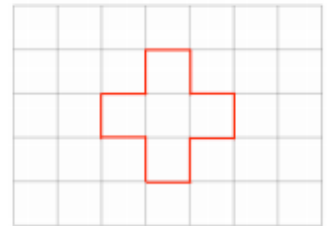

Enlarge by scale factor 4

Question 4: Shown below is an object and its enlargement.
For each, write down the scale factor of enlargement.

(a)

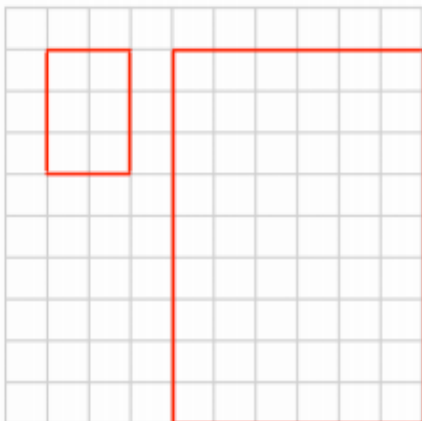

(b)

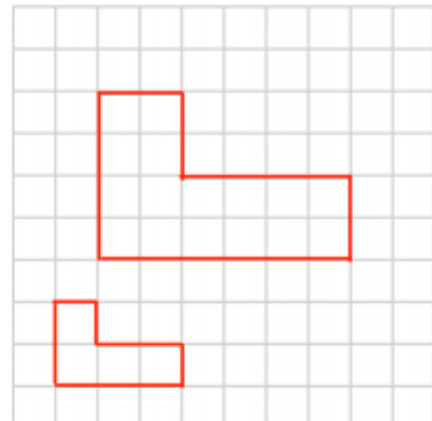

Question 2: Enlarge each shape by the scale factor given
Use P as the centre of enlargement.

(a)

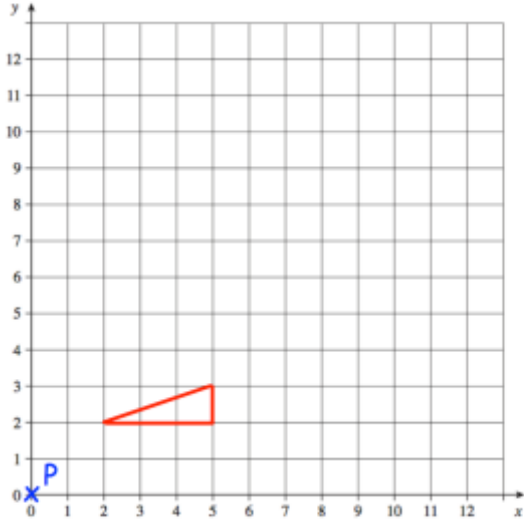

Enlarge by scale factor 2

(b)

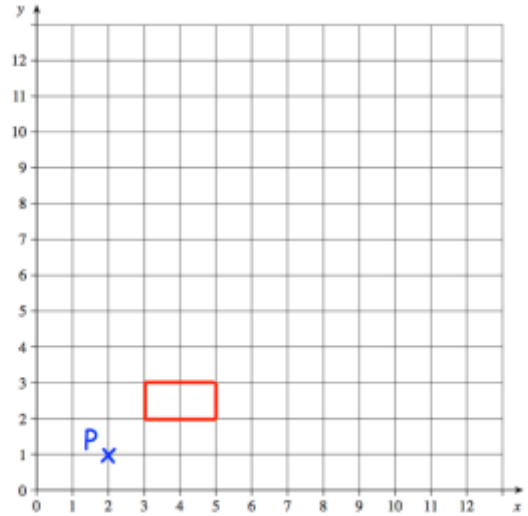

Enlarge by scale factor 3

(c)

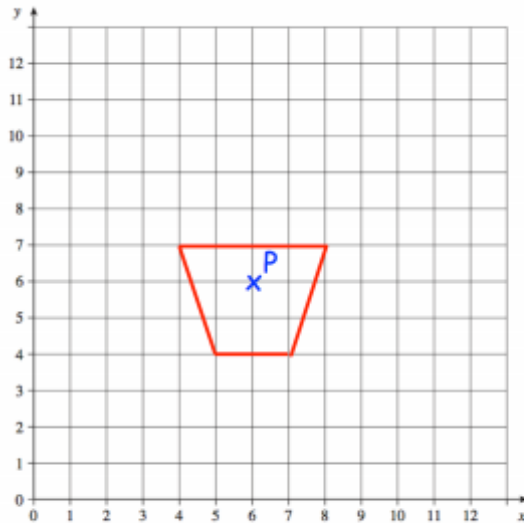

Enlarge by scale factor 3

(d)

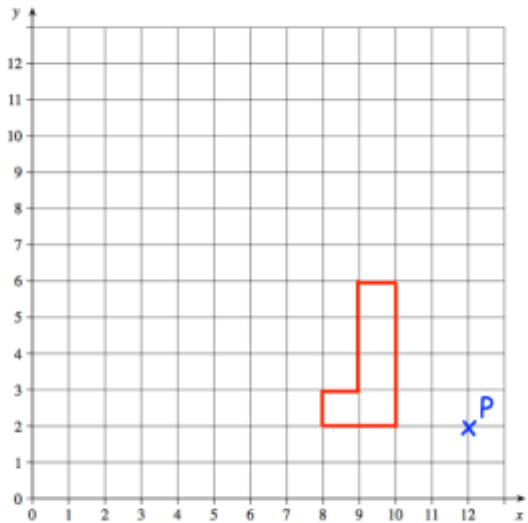

Enlarge by scale factor 2

Question 4: Describe fully the single transformation that takes shape A to shape B.

(a)

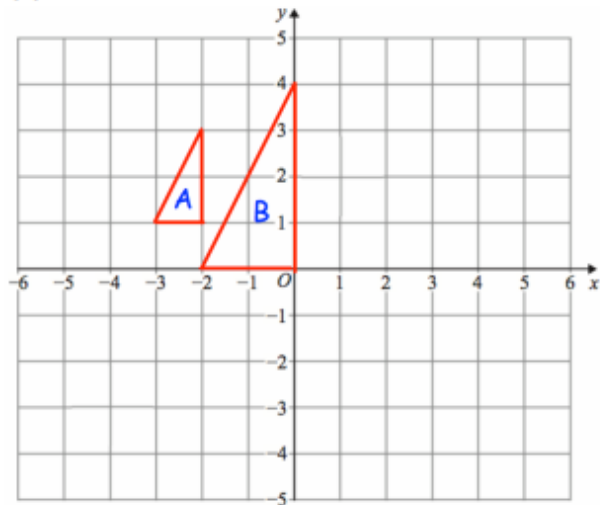

(b)

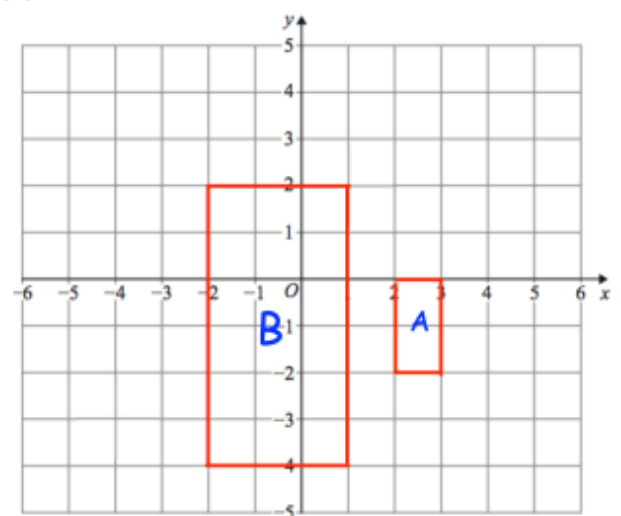

(c)

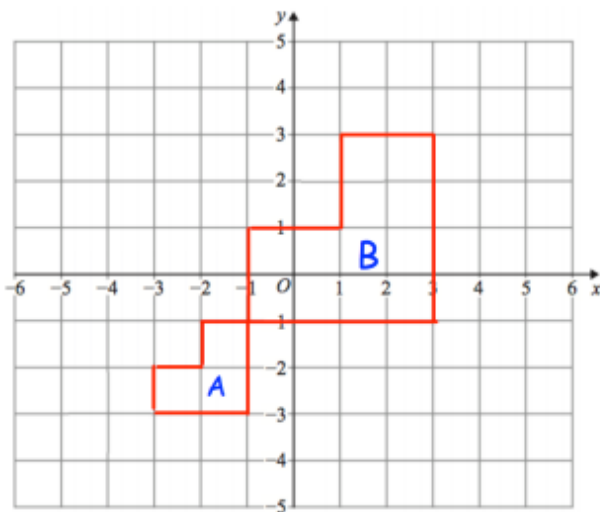

(d)

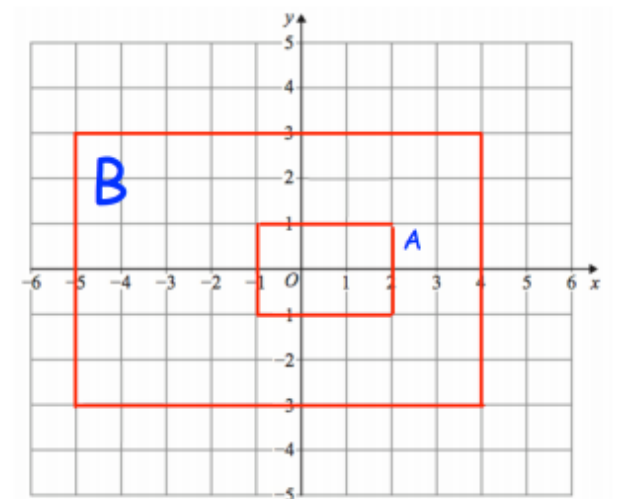

Question 1: Shown is a rectangle drawn on a centimetre squared grid.

- Find the area of the rectangle.
- Enlarge the rectangle by scale factor 2 on centimetre squared paper.
- Find the area of the enlarged rectangle.
- How many times larger is the area of the enlarged rectangle than the original?

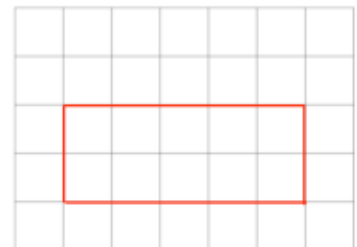

Week 5:

- LI: I can enlarge a shape on a coordinate grid using a fractional scale factor

Demonstration Videos:

<http://corbettmaths.com/2013/03/31/enlargments-fraction/>

Tasks:

Question 1: Copy these shapes and then enlarge by the scale factor given.

(a)



Enlarge by scale factor $\frac{1}{2}$

(b)



Enlarge by scale factor $\frac{1}{3}$

(c)

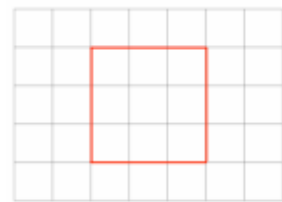

Enlarge by scale factor $\frac{2}{3}$

Question 2: Copy these shapes and then enlarge by the scale factor given.

(a)

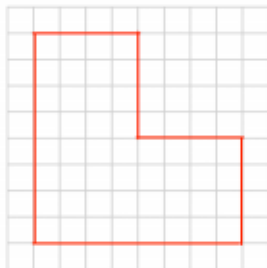

Enlarge by scale factor $\frac{1}{4}$

(b)



Enlarge by scale factor $\frac{1}{2}$

(c)

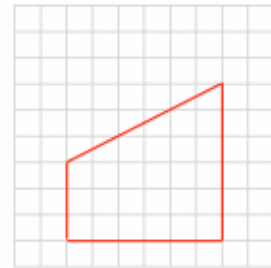

Enlarge by scale factor $1\frac{1}{3}$

Question 3: Enlarge each shape by the scale factor given
Use P as the centre of enlargement.

(a)

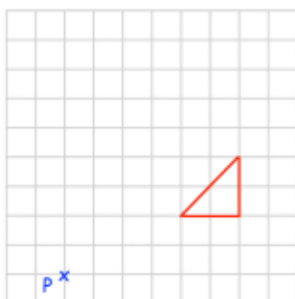

Enlarge by scale factor $\frac{1}{2}$

(b)

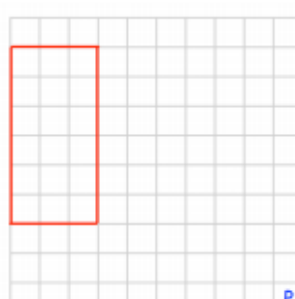

Enlarge by scale factor $\frac{1}{3}$

(c)

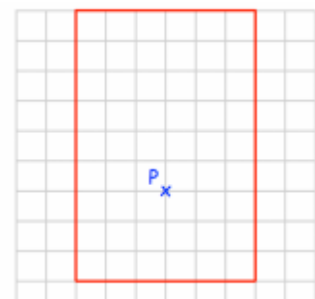

Enlarge by scale factor $\frac{2}{3}$

Question 4: Enlarge each shape by the scale factor given
Use P as the centre of enlargement.

(a)



Enlarge by scale factor $\frac{1}{4}$

(b)

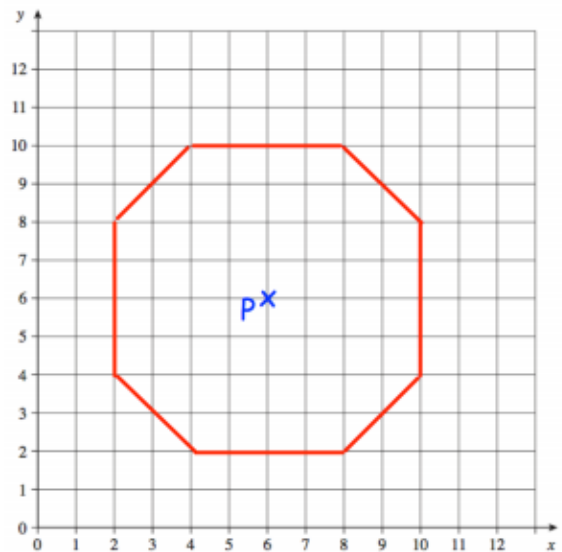

Enlarge by scale factor $\frac{1}{2}$

Question 5: Enlarge each shape by the scale factor given
The coordinates for each centre of enlargement are given.

(a)

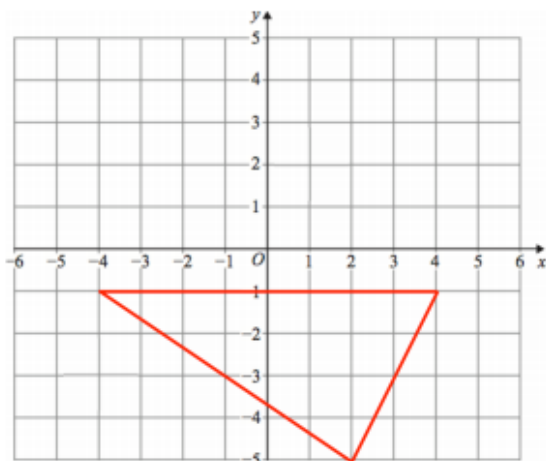

Enlarge by scale factor $\frac{1}{2}$ using
(0, 1) as the centre of enlargement

(b)

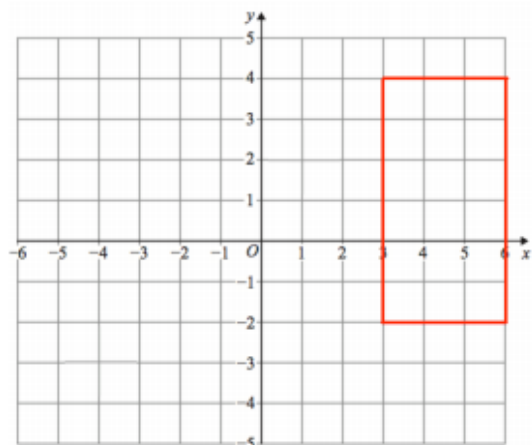

Enlarge by scale factor $\frac{1}{3}$ using
(-3, 1) as the centre of enlargement

Question 6: Describe fully the single transformation that takes shape A to shape B.

(a)

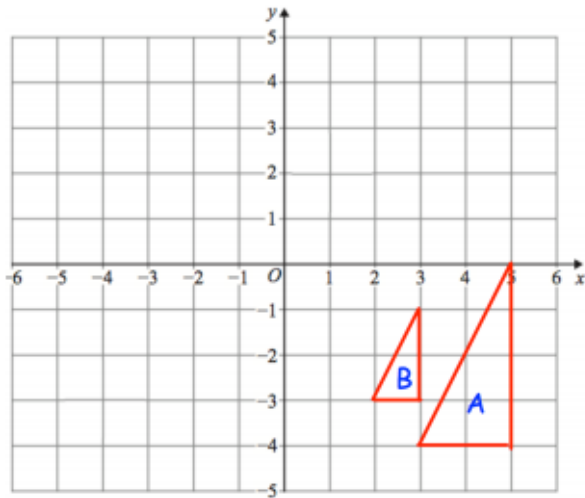

(b)

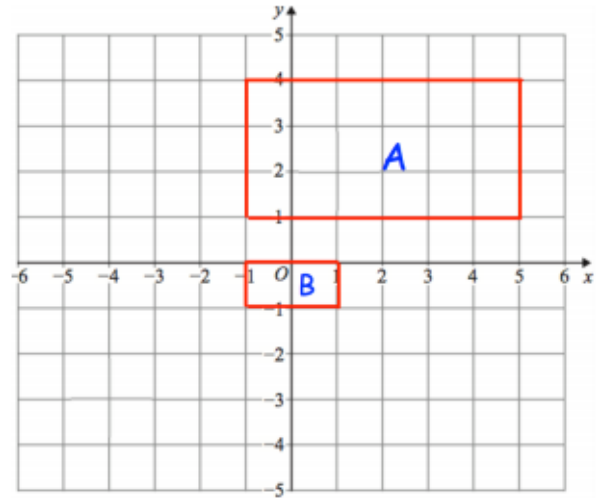

(c)

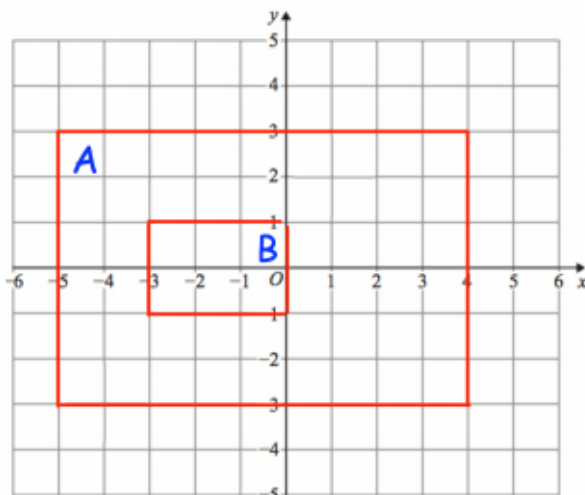

(d)

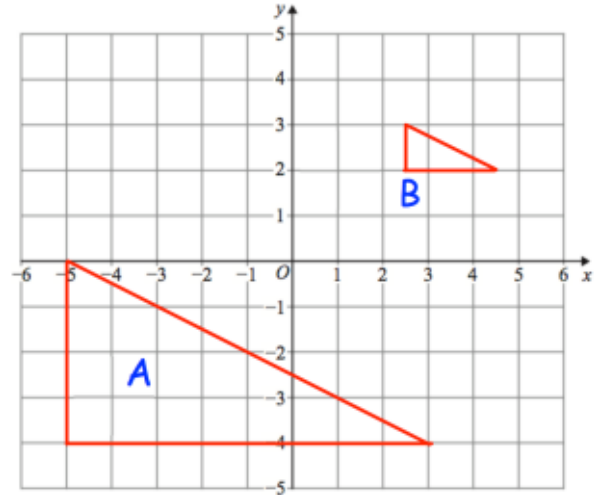

Jack writes:

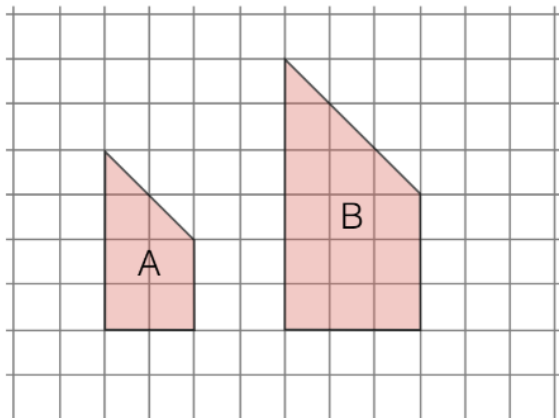

Shape B is an enlargement of A by a scale factor 1.5, because each side gets 1.5 times longer.

Shape A is therefore an enlargement of B by scale factor 0.5.

Jack has made a mistake. What is it?

Week 6:

- LI: I can enlarge a shape on a coordinate grid using a negative scale factor

Demonstration Videos:

<http://corbettmaths.com/2013/04/24/enlargements-with-negative-scale-factor/>

Tasks:

Question 1: Enlarge each shape by the scale factor given
Use P as the centre of enlargement.

(a)

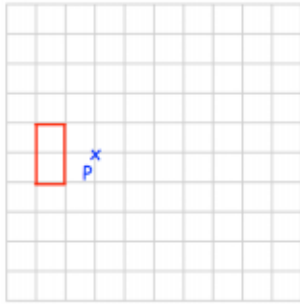

Enlarge by scale factor -3

(b)



Enlarge by scale factor -2

(c)



Enlarge by scale factor -4

(d)

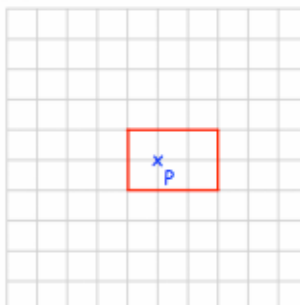

Enlarge by scale factor -2

(e)

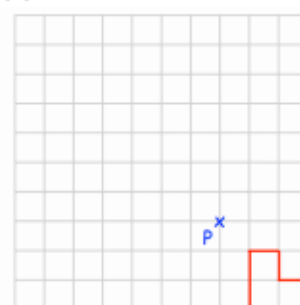

Enlarge by scale factor -2

(f)

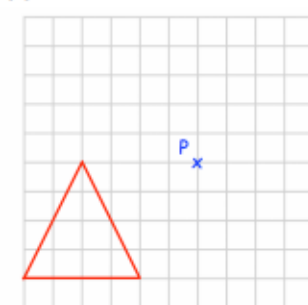

Enlarge by scale factor $-\frac{1}{2}$

Question 2: Enlarge each shape by the scale factor given
Use P as the centre of enlargement.

(a)

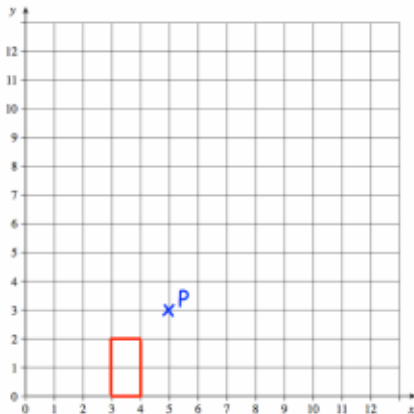

© COI Enlarge by scale factor -3

(b)

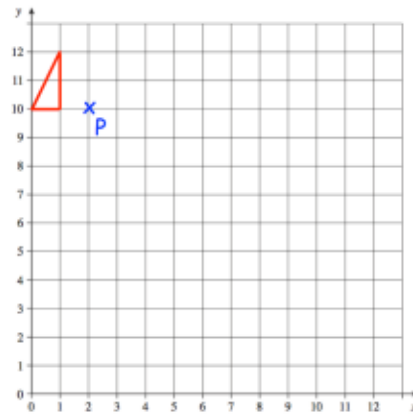

Enlarge by scale factor -4

Question 3: Enlarge each shape by the scale factor given
The coordinates for each centre of enlargement are given.

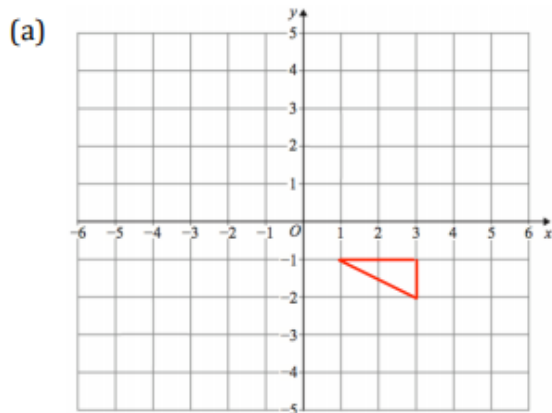

Enlarge by scale factor -2 using $(0, 0)$ as the centre of enlargement

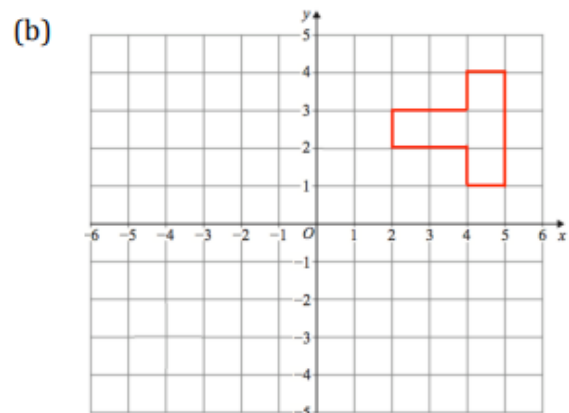

Enlarge by scale factor -2 using $(2, 2)$ as the centre of enlargement

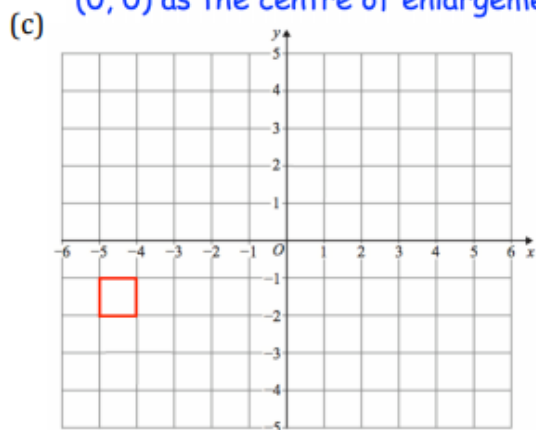

Enlarge by scale factor -4 using $(-3, -1)$ as the centre of enlargement

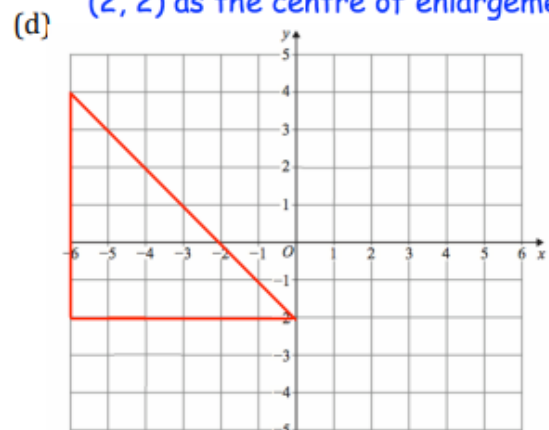

Enlarge by scale factor $-\frac{1}{2}$ using $(0, -2)$ as the centre of enlargement

Question 4: Describe fully the single transformation that takes shape A to shape B.

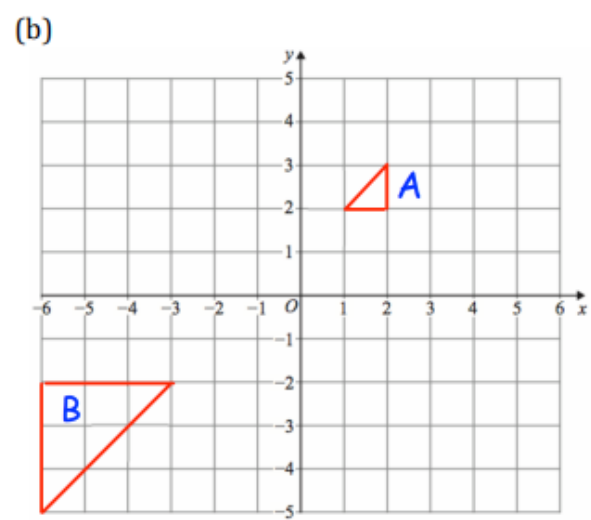
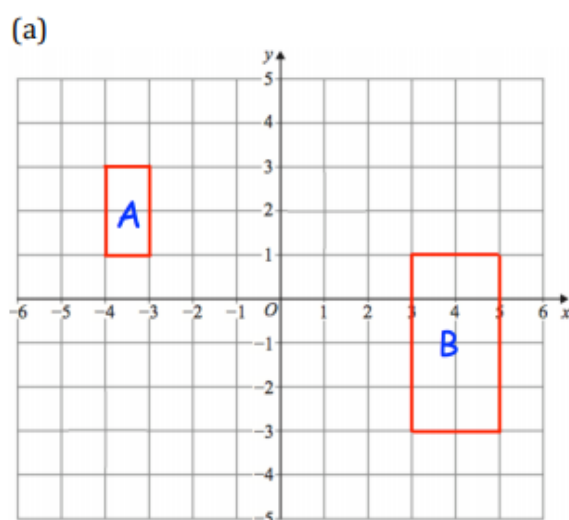

Week 6:

- LI: I can calculate the area of a sector

Demonstration Videos:

<http://corbettmaths.com/2012/08/02/area-of-a-sector-video/>

Tasks:

Question 1: Calculate the area of each of the following sectors.
Give each answer to one decimal place and include units.

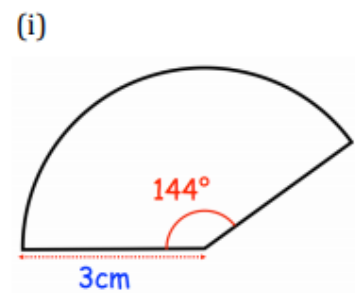
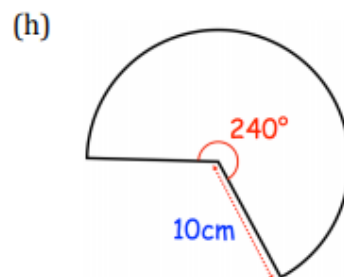
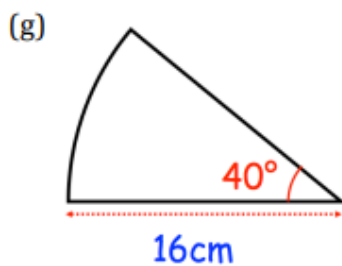
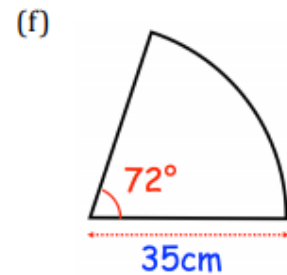
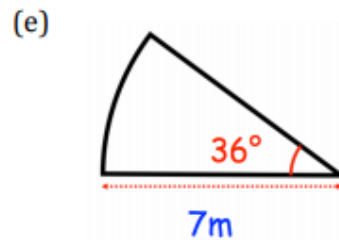
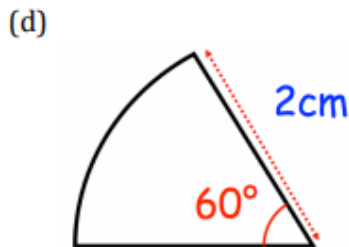
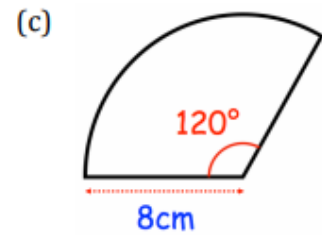
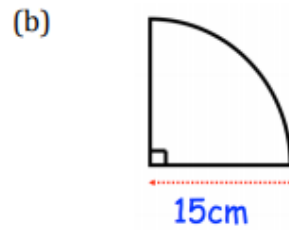
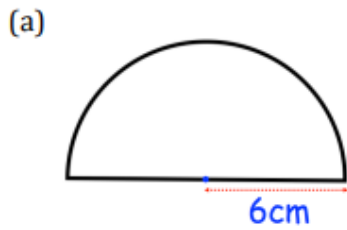

Question 2: Calculate the area of each of these sectors.
Give each answer to 2 decimal places and include suitable units.

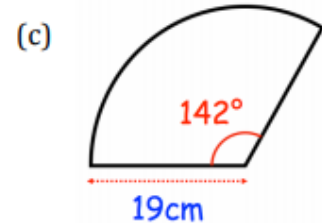
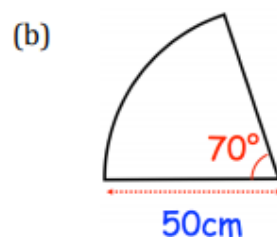
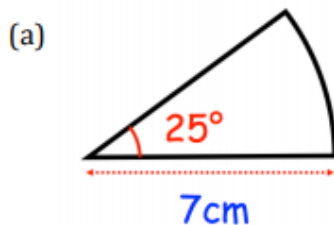

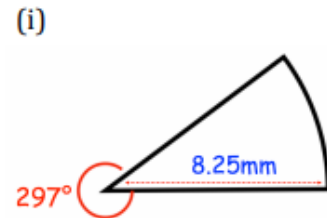
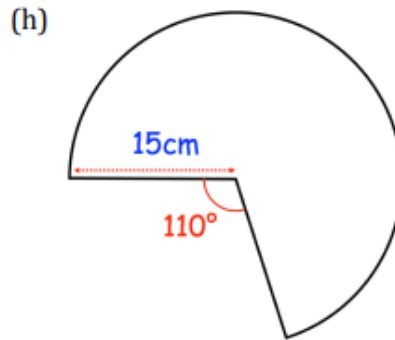
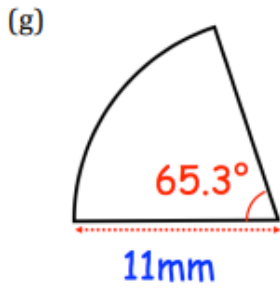
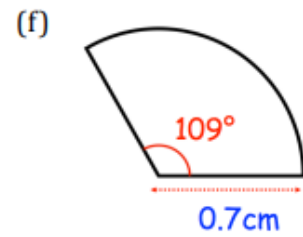
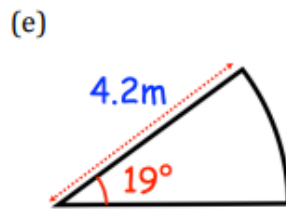
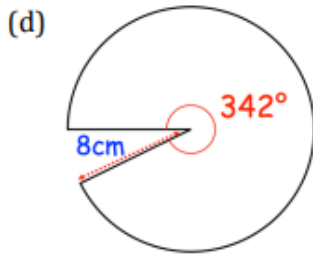

Question 3: Find the area of these sectors.
Leave your answer in terms of π

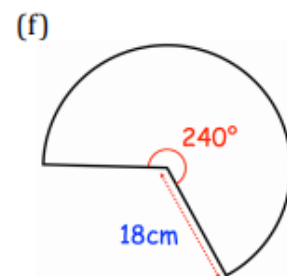
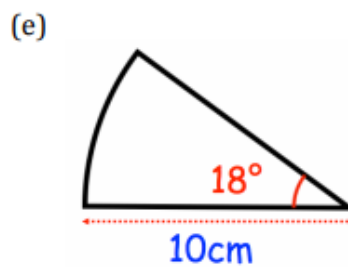
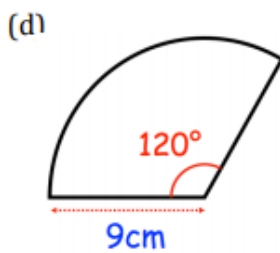
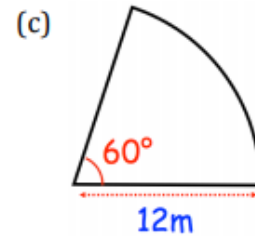
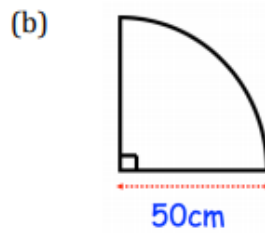
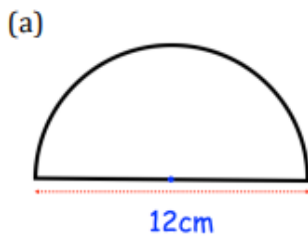

The diagram shows a sector of a circle.

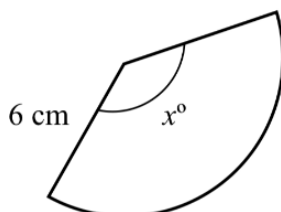

The area of the sector is $14\pi \text{ cm}^2$.
Find the angle x .

Week 6:

- LI: I can calculate the length of an arc

Demonstration Videos:

<http://corbettmaths.com/2013/03/26/arc-length/>

Tasks:

Question 1: For each sector below, calculate the length of the arc.
Give your answers to one decimal place and include suitable units.

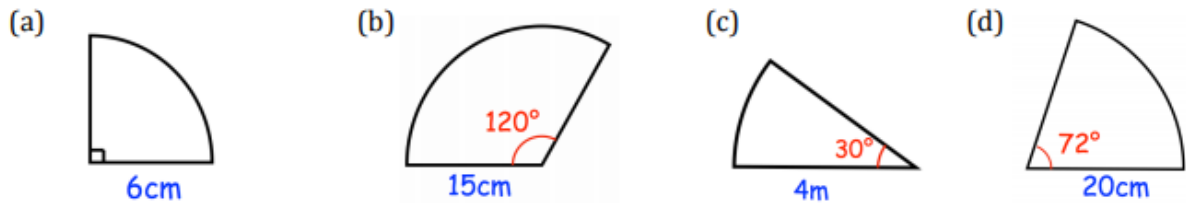

Question 2: For each sector below, calculate the length of the arc.
Give your answers to one decimal place and include suitable units.



Question 3: For each sector below, calculate the length of the arc.
Leave your answer in terms of π

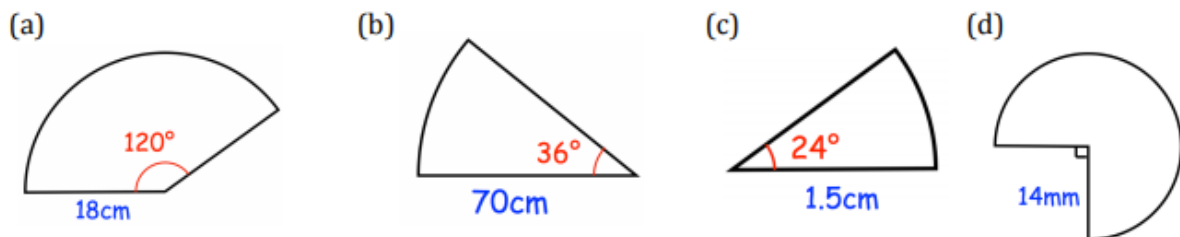

Question 4: Calculate the perimeter of each sector below
Give your answers to one decimal place and include suitable units.

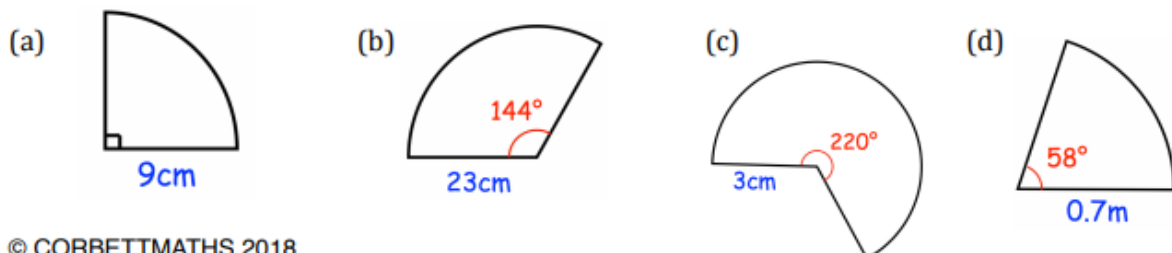

Question 5: Calculate the perimeter of each sector below
Leave your answer in terms of π

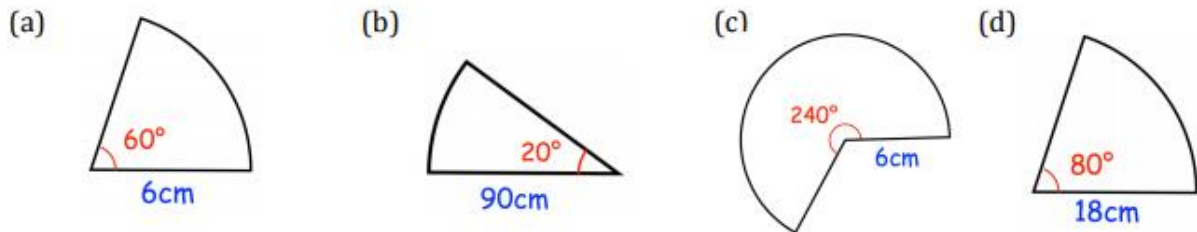

Question 6: The arc length of each sector has been given.
Calculate x
Give your answers to one decimal place and include suitable units.

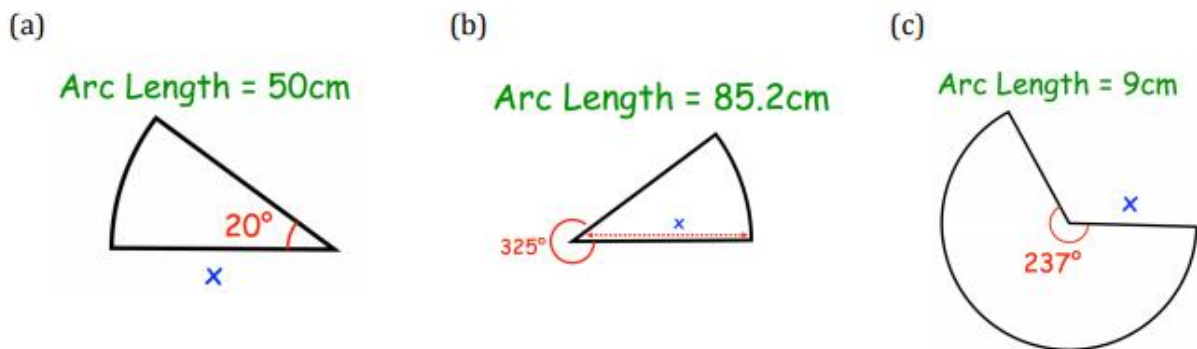

Question 7: The arc length of each sector has been given.
Calculate x

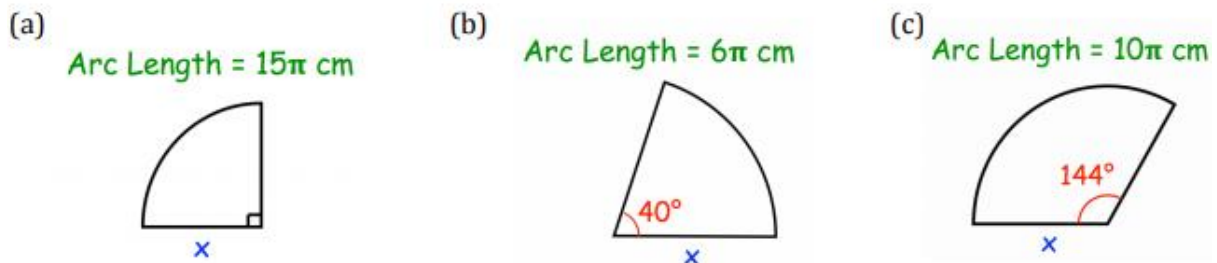

Question 8: The arc length of each sector has been given.
Calculate the size of the angle
Give your answers to one decimal place.

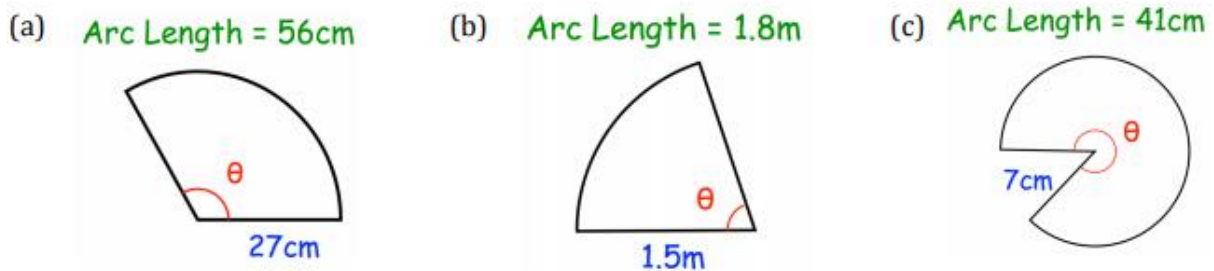



Questions	Question Title
1	Writing inequalities from number lines
2	Writing a percentage as a ratio
3	Finding the n th term of a linear sequence
4	Lines parallel to the y -axis
5	Expanding double brackets
6	Square numbers and powers
7	Median of grouped data
8	Multi-step angle problems
9a	Changing the subject of a formula
9b	Units of speed and acceleration
10	Constructing locus of points equidistant from two points
11a	Completing a frequency tree
11b	Reverse percentages
12a	Calculating time given speed and distance
12b	The effect of speed on time
13	Drawing a box plot
14a/b	Venn diagrams for probability
15	Highest common factor of expressions
16	Substituting into functions
17	Sharing in a ratio
18	Expanding brackets and simplifying
19	Alternate segment theorem
20	Percentage increase and decrease, writing inequalities
21	Prime factor decomposition, index rules
22	Cosine rule
23	Representing inequalities on a graph
24	Ratio problems
25	Instantaneous rate of change
26	Prime numbers problem solving
27	3D trigonometry
28	Exponential decay
29	Quadratic inequalities on a graph
30	Evaluating composite functions